

ARTESYN LCM24K

24 kW Greenhouse System

Centralized Power for LED Horticulture Lighting

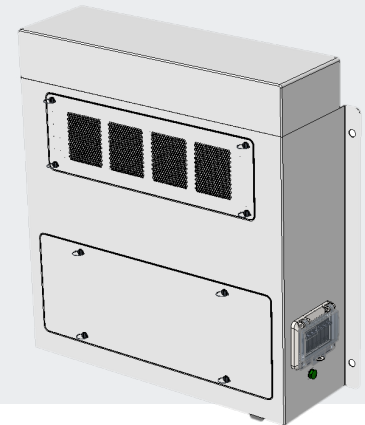

AT A GLANCE

Total Power

24 kW

Input Voltage

Same as LCM12K:

200 to 240 VAC Single Phase

180 to 264 VAC Three Phase

342 to 528 VAC Three Phase

540 to 660 VAC Three Phase (WYE with Neutral)

Output

Per PSU LCM4000HV:

Voltage source: 100 to 300 VDC

Current source: 0 to 16 A

SPECIAL FEATURES

- Wide input voltage range
- High efficiency: up to 95%
- Industrial safety
- Five-year warranty
- Low cost

LCM4000HV:

- 4000 W output power
- 480 mm x 140 mm x 40.3 mm
- 24 Watts per cubic inch
- Variable speed "Smart Fans"
- Optional dust filter available
- DSP controlled
- Digital and analog communication

- Scales easily (Module/Shelf/Rack)
- Meets DLC 2.1 requirements
- Supports Artesyn iTS and IHLC

LCM24K:

- Accepts 4 types of input configurations (Single Phase High Line 200 to 240VAC, 3-PH delta 4W, 3-PH wye 4W, 3-PH wye 5 W)
- Houses six 4 kW power modules
- 633 mm x 655 mm x 170 mm

COMPLIANCE

- EMI Class A
- EN61000 Immunity
- RoHS 3

SAFETY

- UL 2416 (US Market)
- CSA 62368 (Canada Market)
- UL 62368-1 Listed
- CSA 62368-1 Listed
- EN 62368-1 Listed
- IEC 62368-1 Listed
- CB Certificate and Report (IEC 62368-1/IEC 60950-1)
- CE (LVD+RoHS)
- UKCA Mark

APPLICATIONS



Retail Store LED Lighting

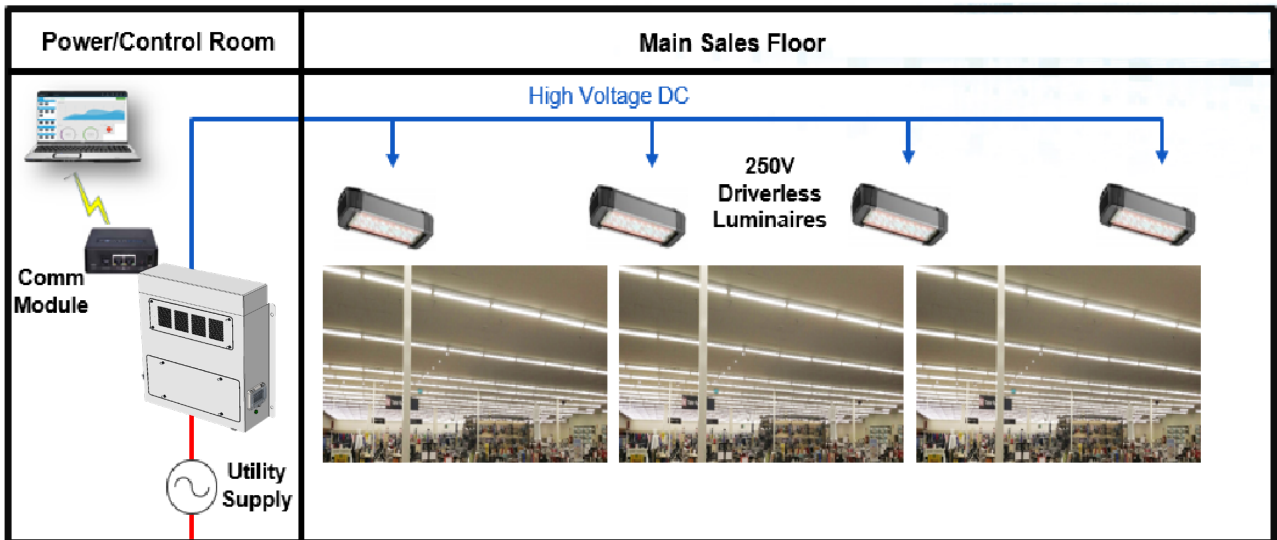

ELECTRICAL SPECIFICATIONS

Input - LCM4000HV	
Input Range ¹	180 to 264 VAC 311 to 528 VAC
Frequency	47 to 63 Hz, Nominal 50/60 Hz
Input Fusing	Both lines fused
Inrush Current	< 60 A peak at 264 VAC, < 60 A peak at 528 VAC
Power Factor	0.99 at 100% load, at both 208 VAC and 480 VAC input
Harmonics	Meets IEC 61000-3-12 requirements
Input Current	25 A max at 180 VAC
No Load Power	35 W max at 180 VAC
Efficiency	95.0% typical at 480 VAC input
Isolation Voltage	Primary to protective earth (PE) = 4000 VDC Primary to secondary = 4000 VDC Secondary to protective earth (PE) = 3200 VDC Primary to user-accessible = 6000 VDC Secondary to user-accessible = 5000 VDC
Input - LCM24K	
Input Range ¹	187 to 264 VAC (1-PH) 180 to 229 VAC (3-PH 4W) 342 to 528 VAC (3-PH 4W. Add Neutral for 600 VAC)
Input Current	140 A max single phase at 187 VAC 90 A max per phase at 180 VAC 50 A max per phase at 342 VAC

Note 1 - Detailed input specifications please refer to ordering information section.

ELECTRICAL SPECIFICATIONS

LCM4000HV Output - Module In Voltage Source Mode		
Nominal Output Voltage	250 VDC	
Maximum Output Current	16 A	
Maximum Output Power	4000 W	
Output Voltage Adjustability Range	100 VDC to 300 VDC	
Output Voltage Adjustment Accuracy	±0.5% of nominal output (via digital command) ±1% of nominal output (via analog command)	Ambient temperature at 23°C ± 5°C (with 30 minutes warm-up period)
Output Static Regulation ¹	0.5% of nominal output (line regulation) 0.75% of nominal output (load regulation)	Ambient temperature at 23°C ± 5°C (with 30 minutes warm-up period)
Line Transient Regulation ^{2,3}	±3% of nominal output voltage	Recovery time of 1 ms at recovery value of 0.5% of nominal output voltage
Load Transient Regulation ²	±5% of nominal output voltage	Load transient at 50 Hz to 5 kHz, duty cycle 10% to 90%, 1 A/us, 50% step load change
Output Voltage Transient Regulation ^{2,4}	±5% of nominal output voltage	Recovery time of 1 ms at recovery value of 0.5% of nominal output voltage
Output Ripple & Noise (peak to peak)	0.5% of nominal output voltage	Measured with 0.1 µF ceramic and 10 µF tantalum capacitor on any output, 20 MHz, at 25°C
Output Voltage Overshoot & Undershoot ⁵	±5% of nominal output voltage ±1% of nominal output voltage	Output current equal or less than 1.6 A Output current more than 1.6 A
Max Output Capacitance	600 µF	
Output Voltage Rise Time	80 ms maximum	Ramp of main output voltage from 0% to 100% of its final setpoint within the regulation band, under any load condition
Hold-up Time	10 ms minimum	Tested at nominal output voltage, maximum output current
Overvoltage Protection (OVP)	First level: 125% of voltage set-point, Secondary level: 130% of max output voltage	Latch Latch
Overload Protection (OCP)	First level: constant current clamp (adjustable up to 104% of maximum output current) Second level: fast latch (set at 115% of maximum output current)	Auto-recovery Latch
Over Temperature Protection (OTP)	Over temperature protected	Auto-recovery
Short Circuit Protection	Short circuit protected	
LCM24K Output - Module In Voltage Source Mode		
Maximum Output Current	96 A (16A per PSU)	
Maximum Output Power	24 kW	

Note 1 - Operate at steady state line and load conditions.
 Note 2 - Minimum dynamic load 1.6 A, maximum test capacitance 470 µF.
 Note 3 - Line transient change at ±10%.
 Note 4 - Occur during an on-the-fly adjustment of output voltage set-point. Slew rate at 4 V/ms.
 Note 5 - Recover within 300 ms, rise is monotonic.

ELECTRICAL SPECIFICATIONS

LCM4000HV Output - Module In Current Source Mode		
Maximum Output Current	16 A	
Output Voltage Range	100 VDC to 300 VDC	
Maximum Output Power	4000 W	
Output Current Adjustability Range	0.48 A to 16 A	Less than 0.48A will be considered as 0A or OFF
Output Current Adjustment Accuracy	±2% of max output current (via digital command) ±2.5% of max output current (via analog command)	Ambient temperature at 23°C ± 5°C (with 30 minutes warm-up period)
Output Static Regulation ¹	1% of max output current (line regulation) 2.5% of max output current (load regulation)	Ambient temperature at 23°C ± 5°C (with 30 minutes warm-up period)
Line Transient Regulation ^{2,3}	±3% of max output current	Recovery time of 1 ms at recovery value of 0.5% of max output current
Output Current Transient Regulation ^{2,4}	±5% of max output current	Recovery time of 1 ms at recovery value of 0.5% of nominal output voltage
Output Ripple & Noise (RMS)	3.5% of maximum output current	Use current probe to measure the ripple current, 20 MHz
Output Current Overshoot & Undershoot ⁵	±1% of nominal output current	Output voltage 100 V and above
Max Output Capacitance	600 uF	
Output Current Rise Time	80 ms maximum	Ramp of main output voltage from 10% to 100% of its final setpoint within the regulation band, under any load condition
Hold-up Time	10 ms minimum	Tested at nominal output voltage, maximum output current
Overvoltage Protection (OVP)	First level: constant voltage clamp (adjustable up to 120% of nominal output voltage)	Auto-recovery
	Second level: fast latch (set at 130% of nominal output voltage)	Latch
Overload Protection (OCP)	First level: 115% of current set-point	Latch
	Secondary level: 120% of max output current	Latch
Over Temperature Protection (OTP)	Over temperature protected	Auto-recovery
Short Circuit Protection	Short circuit protected	
LCM24K Output - Module In Current Source Mode		
Maximum Output Current	96 A (16 A per PSU)	
Maximum Output Power	24 kW	

Note 1 - Operate at steady state line and load conditions.

Note 2 - Minimum dynamic load is equivalent to 40% of nominal output voltage, maximum test capacitance 470 uF.

Note 3 - Line transient change at ±10%.

Note 4 - Occur during an on-the-fly adjustment of output current set-point. Slew rate at 4% of I_{out-max} per ms.

Note 5 - Recover within 300 ms, rise is monotonic.

ELECTRICAL SPECIFICATIONS

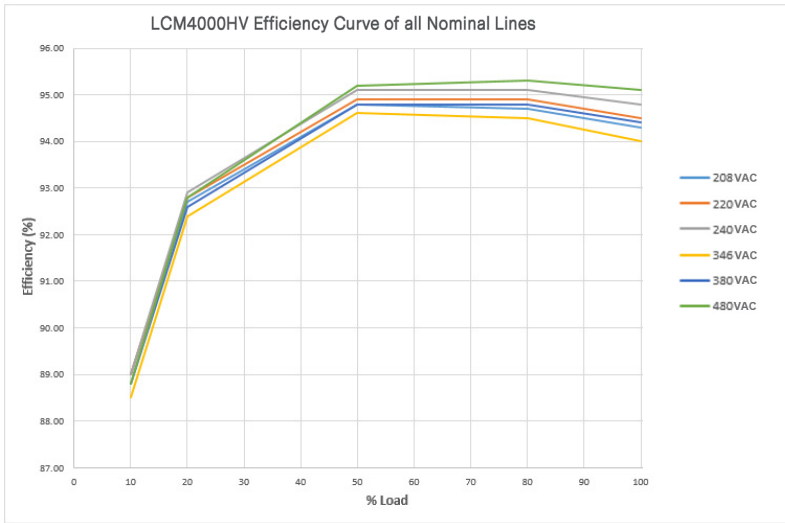

Load %	Efficiency (%)					
	208 VAC	220 VAC	240 VAC	346 VAC	380 VAC	480 VAC
10	89.00	89.00	89.00	88.50	88.80	88.80
20	92.70	92.80	92.90	92.40	92.60	92.80
50	94.80	94.90	95.10	94.60	94.80	95.20
80	94.70	94.90	95.10	94.50	94.80	95.30
100	94.30	94.50	94.80	94.00	94.40	95.10

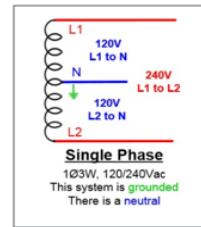
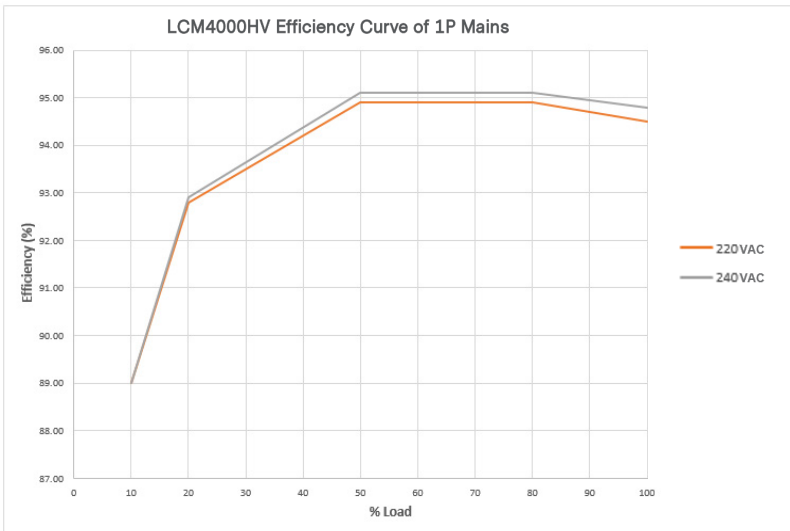

- 220 VAC (nominal)
- 240 VAC (nominal)

Load %	Efficiency (%)	
	220 VAC	240 VAC
10	89.00	89.00
20	92.80	92.90
50	94.90	95.10
80	94.90	95.10
100	94.50	94.80

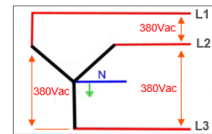
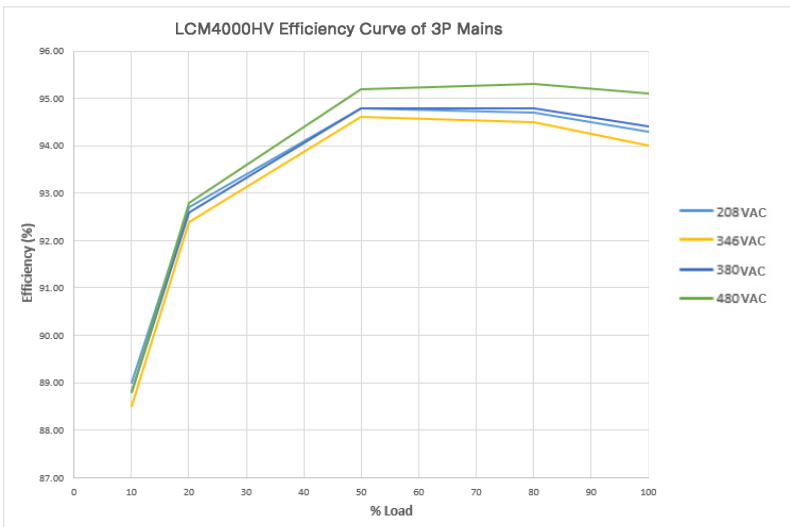

- 208 VAC (nominal)
- 380 VAC (nominal)
- 480 VAC (nominal)

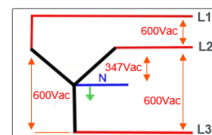

- 347 VAC (nominal)

Load %	Efficiency (%)			
	208 VAC	346 VAC	380 VAC	480 VAC
10	89.00	88.50	88.80	88.80
20	92.70	92.40	92.60	92.80
50	94.80	94.60	94.80	95.20
80	94.70	94.50	94.80	95.30
100	94.30	94.00	94.40	95.10

ENVIRONMENTAL SPECIFICATIONS

Operating Conditions	
Operating Temperature	0°C to 50°C at 100% rated load, 50°C to 60°C derate to 3200 W
Storage Temperature	-40°C to 85°C
Operating Humidity	20% to 90% non condensing
Storage Humidity	10% to 95% non condensing
Operating Altitude	Up to 9,842 feet above sea level (3,000 meters)
Storage Altitude	Up to 30,000 feet above sea level (9,144 meters)
Shipping and Handling	NSTA for <100 lbs; MIL-STD-2073-1 >100 lbs
Cooling	Internal fan with variable speed control
Vibration and Shock	IEC068-2 / IEC721-3 Standard & Levels

ORDERING INFORMATION

Model Number	Cabinet Feature	Output Power
FC02UCAB1-024-G	02U NEMA 3R, Wall Mount	Two LCM12K Shelves, 24 kW

Note 1 - The enclosure will have a single AC input that will accommodate the AC input range of the LCM12K series.

Note 2 - Refer to LCM4000HV/LCM12K datasheet for the detailed electrical specifications.

FCxxxCAB#-yyy-z-4xx Part Number Scheme

xxx	#	yyy	z	4xx
Cabinet size: 06U, 10U, 14U or 18U	Cabinet features: 0 = Standard cabinet, free standing 1 = NEMA 3R, wall mount 2 = Standard cabinet, wall mount	Total output power of the configured cabinet, measured in 4KW increments. This also defines the # of LCM12K shelves installed.	# of PDUs installed. One PDU for every 36KW/ 3 shelves 0 = DIN rail option. Details in MOD G = Liquid tight connections	Customer specific MODs

MECHANICAL DRAWINGS - LCM24K

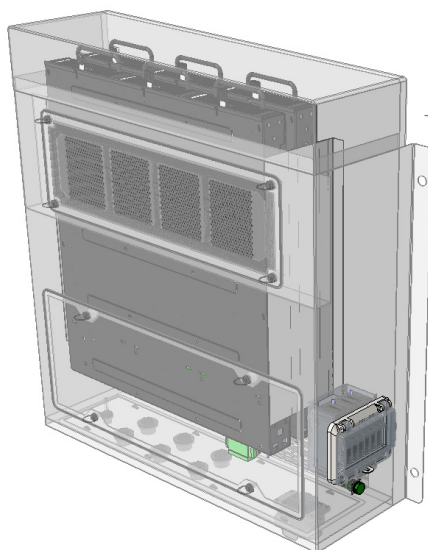
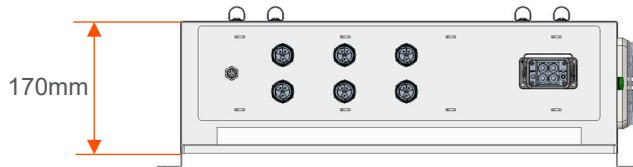
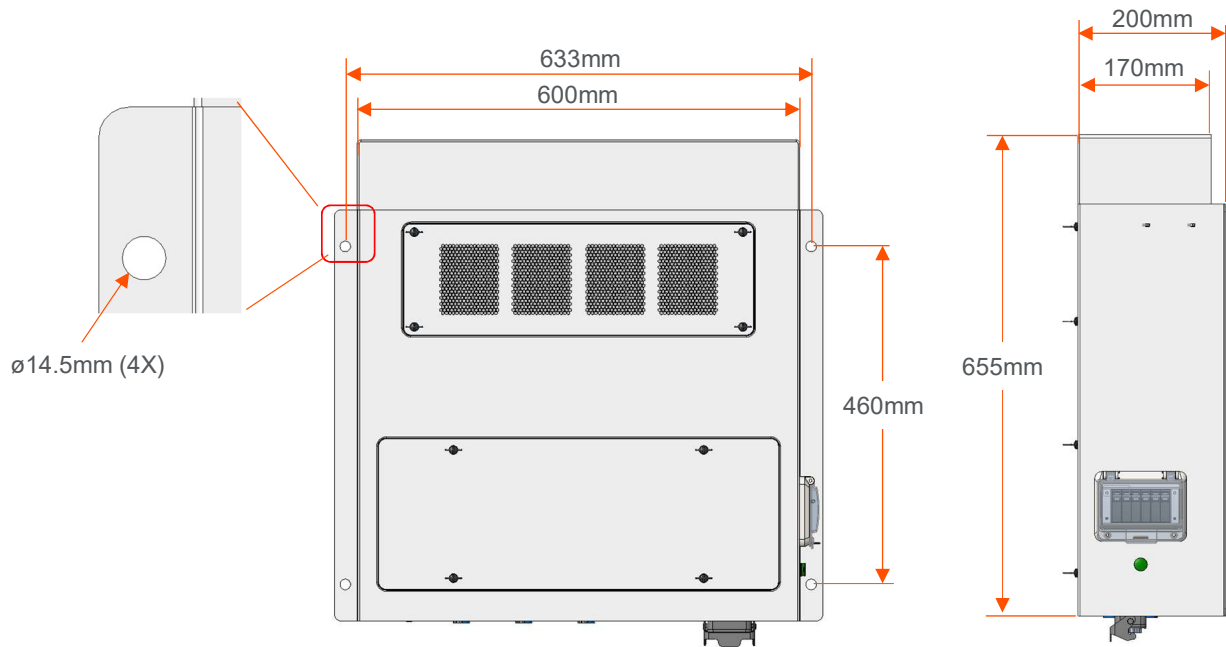

2 x LCM12K shelves
 6 x LCM4000HV PSUs
 Estimated weight is 40 kg (including 6pcs of PSU, around 3 kg/pcs)
 Note: Enclosure assembly and LCM4000HV PSUs are to be shipped separately.

REMOVABLE DOOR DRAWINGS

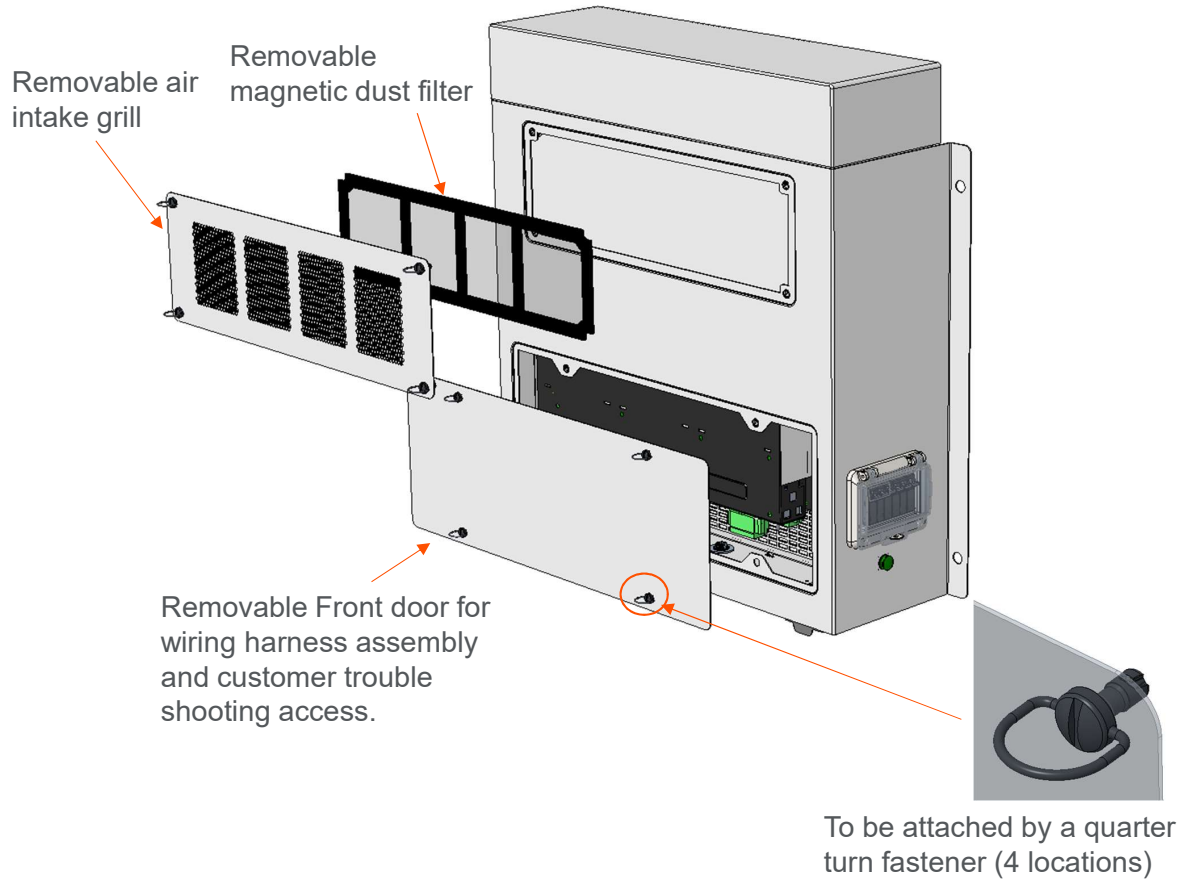

Quarter Turn Fastener
Southco D8-316-410-191

Panel/Door

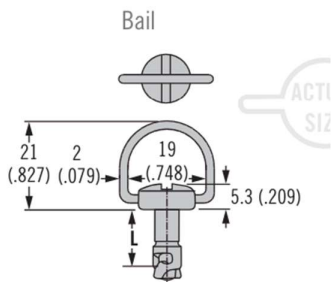

Main Enclosure

Press-In - Self-Clinching

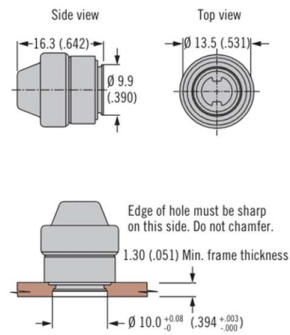

PSU INSTALLATION PROCESS

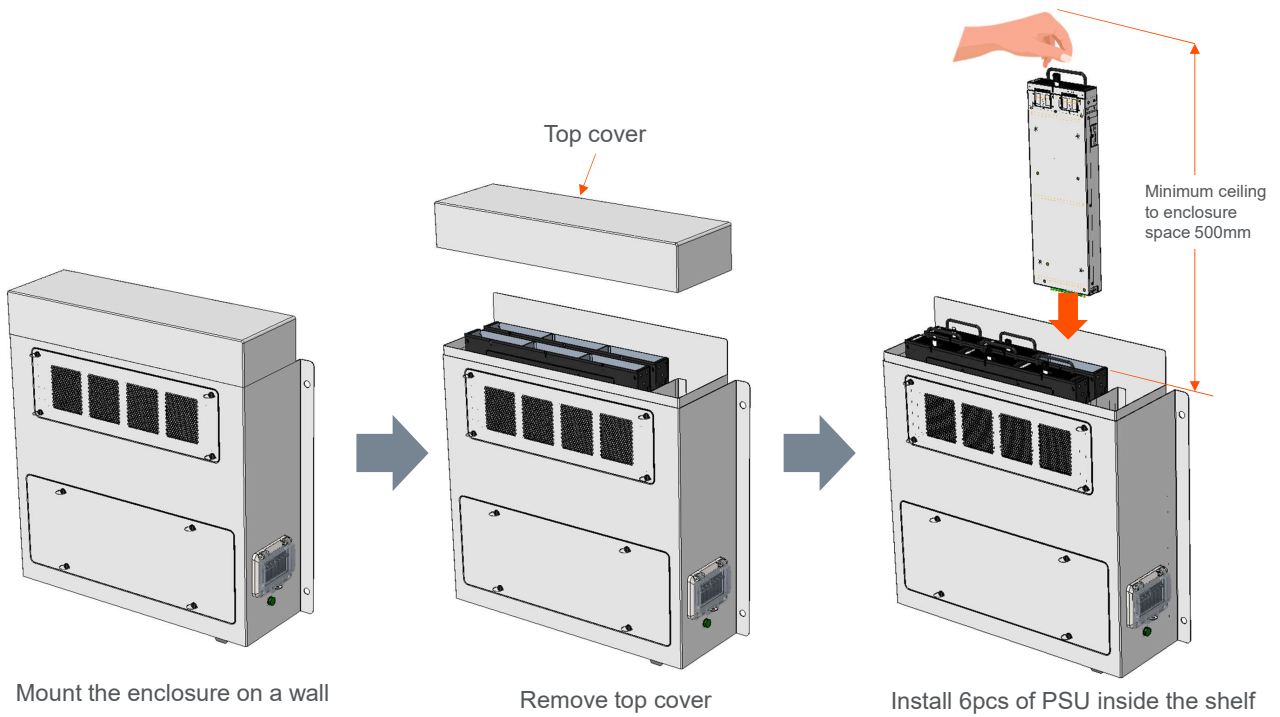

AIR VENT INDICATION

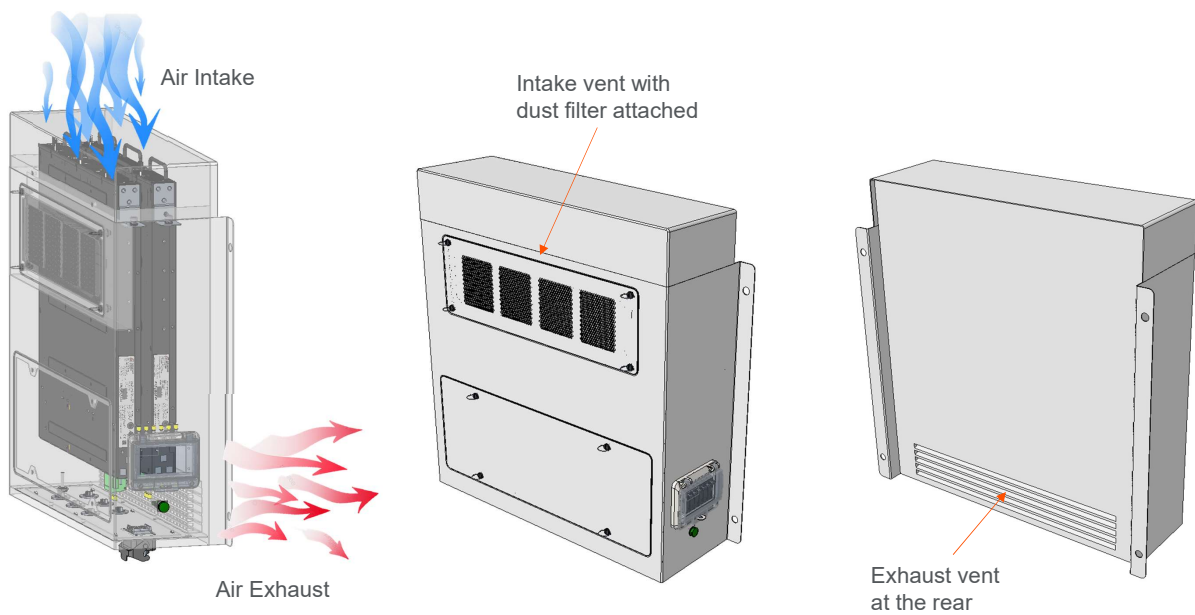

PANEL LAYOUT

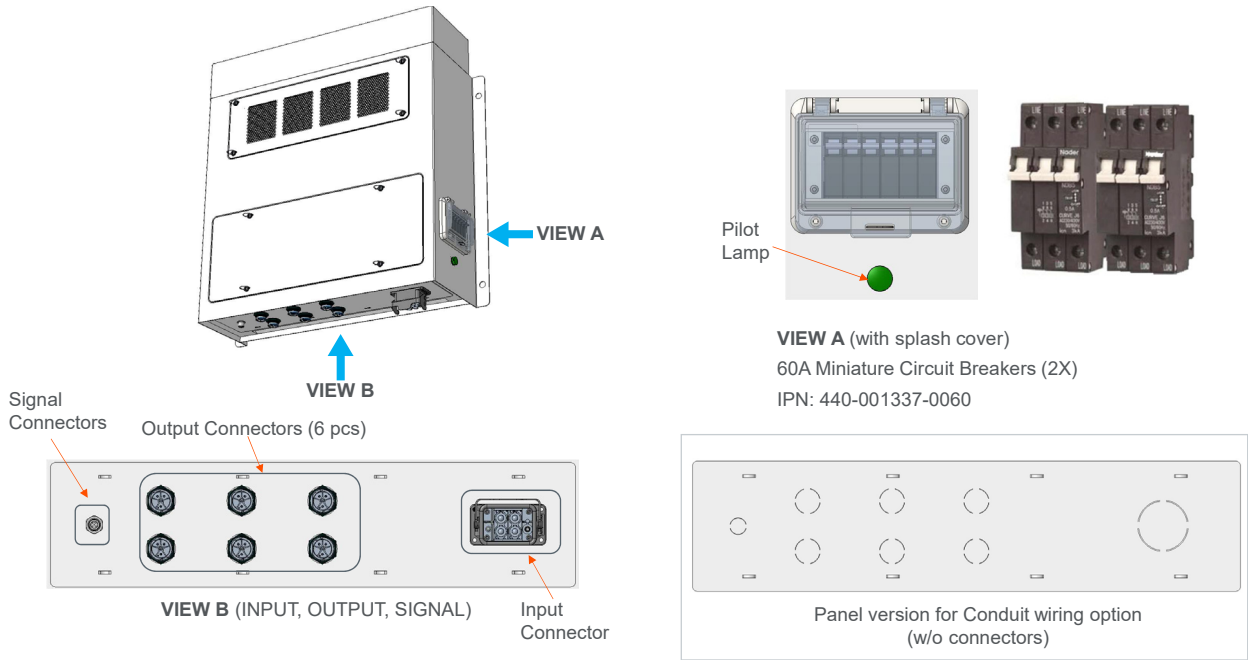

MATING CONNECTORS

Input Connector Detail
Vendor: AMPHENOL

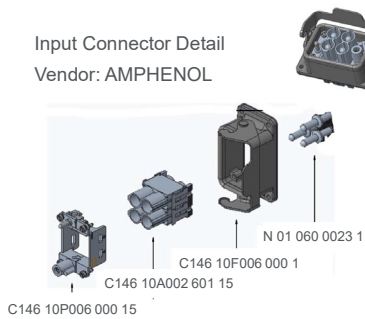

Mating Parts:



Output Connector Detail

Vendor: AMPHENOL
MPN: DC-03PMFS-QC800P (3 Pins)



Mating Part No: DC-03BFMA-QL8APP (3 Pins)



Comms Connector Detail

Vendor: Molex 1200845107 (4 Pins)



Mating Part: Molex 1200845108 (4 Pins)



PIN ASSIGNMENT - LCM24K

Input Connector

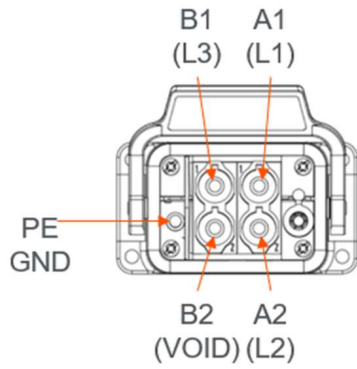

Pin Number	Function	Description
A1	L1	AC-in Phase 1
A2	L2	AC-in Phase 2
B1	L3	AC-in Phase 3
B2	VOID	Unassigned
-	PE (Ground)	Protective Earth

Output Connector



Pin Number	Function	Description
1	+250V	250 V Positive Supply
2	GND	Ground
3	RTN_250V	250 V Return

Signal Connector

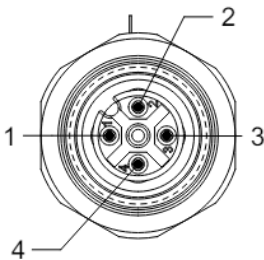

Pin Number	Function	Description
1	RS485_A_EXT	RS485 comm line
2	RS485_B_EXT	RS485 comm line
3	NA	Unassigned
4	RTN_RS485	RTN for RS485

LCM4000HV MODULE DRAWINGS

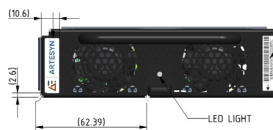
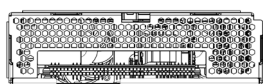
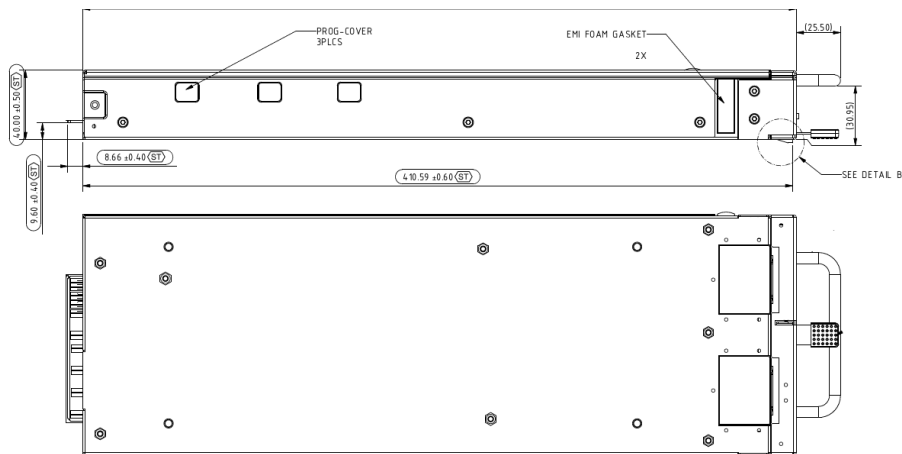
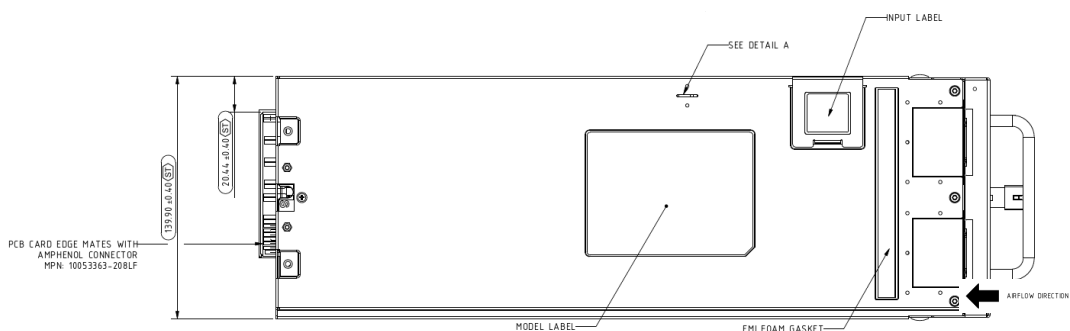
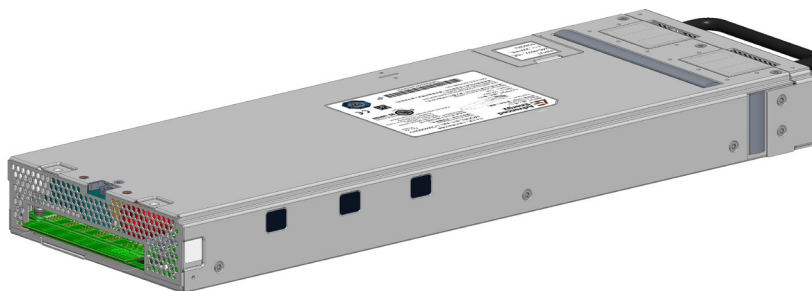

LCM4000 GDT ENABLING AND DISABLING

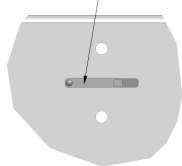

DETAIL A

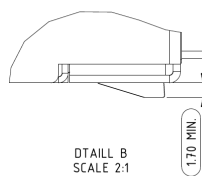

DETAIL B
SCALE 2:1

OUTPUT DISTRIBUTION TO LIGHTS

The output distribution from the LCM12K shelves to the light fixtures needs to be designed to be flexible yet standardized

Circular Connector

The system should have an option of routing the outputs to a series of circular connectors. The outputs will need to be labeled so that the installer can follow the site plan to connect the lights to the corresponding modules.



Electrical Knockout option

The installer may use conduit to route the outputs to the lights. In this case, there will need to be a means to easily connect electrical conduit connectors to the bottom of the enclosure. There should be six (6) knockouts to accommodate 1/2" trade size conduit connectors and one (1-) 3/4" trade size. The purpose of the 3/4" is to accommodate an installation that will route all lighting wires in a single conduit. Knockouts can be a combination 1/2" and 3/4" if that is easier.



Example of 1/2" and 1/2" & 3/4" Combination Knockouts

For this option, there shall be a terminal block within the enclosure that the electrician can easily access to connect the (+) and (-) wires for each output as well as a suitable ground terminal block. The terminal block should be labeled to indicate which of the 6 LCM4000HV modules are connected.

Below are examples of acceptable terminal blocks.

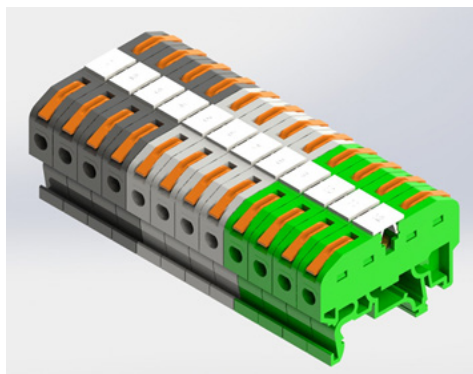

Quick Connect Terminal Block

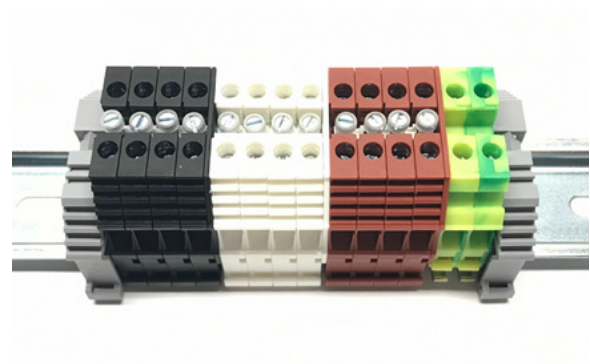

Screw Type Terminal Block

MISCELLANEOUS SPECIFICATIONS

Ground Connection

The system should include ground connections from LCM12K shelves to the site earth ground connection through the AC input connection.



Ground Terminal Block Example

MTBF

The power supply has a minimum MTBF of 200K hours using the Telcordia specifications @ 25 °C ambient at full load, nominal line of 220V/240 VAC. With the power supply installed in a system in a 35 °C ambient environment and operating at full load, capacitor life will be 5 years minimum for ALL electrolytic capacitors contained within this power supply. The power supply will demonstrate an MTBF level of > 500,000 hours based on actual field population operational hours.

QUALITY ASSURANCE

Full QAV testing is conducted in accordance with Advanced Energy's Artesyn Standards with reports available upon request.

WARRANTY

Advanced Energy's Artesyn Embedded Power warrant the power supply to be free of defects in materials and workmanship for a minimum period of five (5) years from the date of shipment, when operated within specifications. The warranty is fully transferable to the end owner of the equipment powered by the supply.



For international contact information,
visit [advancedenergy.com](https://www.advancedenergy.com).

powersales@aei.com (Sales Support)
productsupport.ep@aei.com (Technical Support)
+1 888 412 7832

ABOUT ADVANCED ENERGY

Advanced Energy (AE) has devoted more than four decades to perfecting power for its global customers. AE designs and manufactures highly engineered, precision power conversion, measurement and control solutions for mission-critical applications and processes.

Our products enable customer innovation in complex applications for a wide range of industries including semiconductor equipment, industrial, manufacturing, telecommunications, data center computing, and medical. With deep applications know-how and responsive service and support across the globe, we build collaborative partnerships to meet rapid technological developments, propel growth for our customers, and innovate the future of power.

PRECISION | POWER | PERFORMANCE | TRUST

Specifications are subject to change without notice. Not responsible for errors or omissions. ©2024 Advanced Energy Industries, Inc. All rights reserved. Advanced Energy®, AE® and Artesyn™ are U.S. trademarks of Advanced Energy Industries, Inc.