

ARTESYN 50 V, 33 KW, 10U OPEN RACK HPR POWER SHELF

33 kW, 27.5 kW (N + 1) or 16.5 kW (N + N)



Advanced Energy's Artesyn introduces the 33 kW, 10U, ORv3 HPR power shelf that converts incoming three phase AC supply voltage into a 50 VDC output with a total power capability of 33 kW continuous output power. It accommodates 6x5.5 kW hot-swappable single phase PSU modules. The Power Shelf inputs are universal 7 pin connectors which can be configured as wye (5-wire 3PH+N+PE), delta (4-wire 3PH+PE) or single phase. It includes a slot for a hot-pluggable shelf communications module, supporting 3 different options for communications and control: Power Management Interface (PMI), Power Management Controller (PMC) or Power Management Module (PMM). Multiple shelves can be operated in parallel, typically enabling applications such as accelerated computing racks requiring 100kW or more of highly regulated 50VDC power.

KEY FEATURES

- 33 kW at 50 V with N + 0 redundancy
27.5 kW at 50 V with N + 1 redundancy
16.5 kW at 50V with N + N redundancy
- Highly accurate shelf droop and/or active current sharing capability
- Houses 6 x 5500 W power modules and a removable shelf control module
- Very high efficiency
- Accepts 3 types of input configurations (3P Delta 4 W, 3P Wye 5 W, 3 x of 1P)

COMPLIANCE

- EN 61000-4-2 Cat-A for surges
- EN 61000-3-2 Class-A for harmonics
- EN55022, FCC Part 15, CISPR 22, Class-A for EMC

SAFETY

- EN 62368-1
- UL 62368-1
- IEC 62368-1
- SEMI F47 Compliance

AT A GLANCE

Total Output Power

Dual Whip Shelf: 33 kW (N + 0)
27.5 kW (N + 1) or 16.5 kW (N + N)

Input Voltage

Nominal Ranges:

346 to 480 VAC 3 phase 5 wire
Wye (3ph + N + E)
200 to 277 VAC 3 phase 4 wire
Delta (3ph + E)

Output Voltage

50.5 VDC

Mechanical Dimensions

720 x 537 x 46 mm (L x W x H)

Operating Temperature

-5 to +45°C

50 V 33 kW 10U ORv3 HPR POWER SHELVES

ELECTRICAL SPECIFICATIONS

INPUT				
	MIN	NOM	MAX	UNIT
Input Voltage (3 phase Delta 4 wire)	180	200/277	305	VAC
Input Voltage (3 phase Wye 5 wire)	360	380/480	528	VAC
Input Voltage (3 x of 1 phase)	180	200/277	305	VAC
OUTPUT				
	MIN	NOM	MAX	UNIT
Set Point VDC (50% Load)	48.825	49.000	49.125	VDC
Output Current	-	-	550	A
Ripple & Noise (@ 20 MHz BW) ¹	-	-	500	mVpp

Note 1: Measured with a 0.1 mF capacitor connected to the probe tip

POWER SHELF INPUT CONFIGURATION

The following section explains the input configuration of the power shelf:

ORv3 10U Power Shelf for 6 x 5.5 kW ORv3 5.5 kW HPR PSU with dual cord (2 x 30A NEC or 32A IEC breaker upstream)

10U shelf with two AC power input

6 x 5.5 kW rectifier slots

Output power: 33 kW with N+0 or 27.5 kW with N+1 or 16.5kW N+N with both input connector powered

Direct connect to tap-boxes/facility – no intermediate PDU.

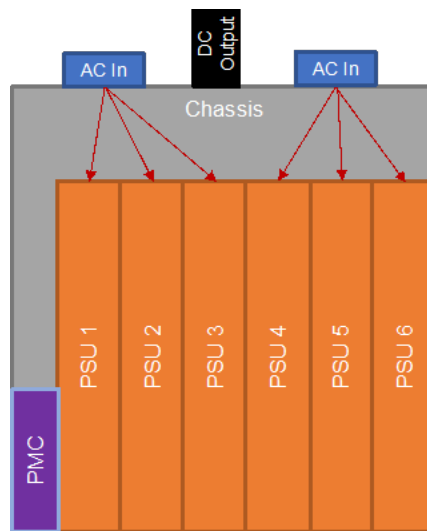

TOP VIEW

MECHANICAL

ORv3 Rack Mounting Features

These power shelves are designed for front mounting into Open Rack V3 racks on OU pitch rails (please refer to the Open Rack V3 specifications on more details for the design of these). The design of the 48 V output connector allows it to be placed in any location in the rack.

Rack mounting features are of particular importance in the power shelf design since they assist in constraining the power shelf in X, Y, and Z directions and promote solid electrical contact with the 48 V busbar.

■ **Front Latch & Bumper**

Please refer to the mechanical CAD for the locations of the front latch and bumper. Note that these serve separate functions and should not be a single part.

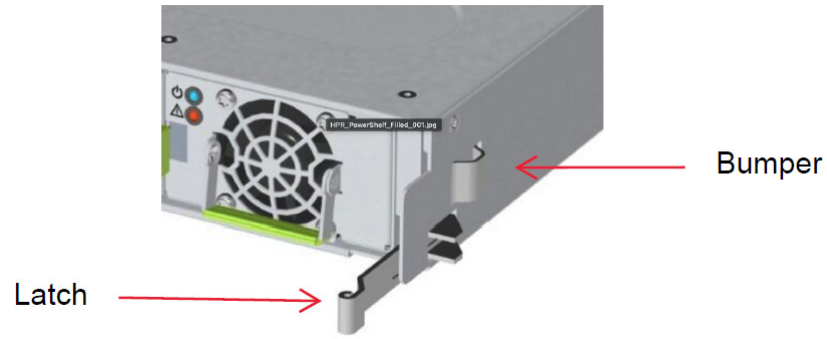

■ **Rear Stop**

Please refer to the mechanical CAD for the geometry of the rear stop. This is required to interface properly with the ORv3 rack

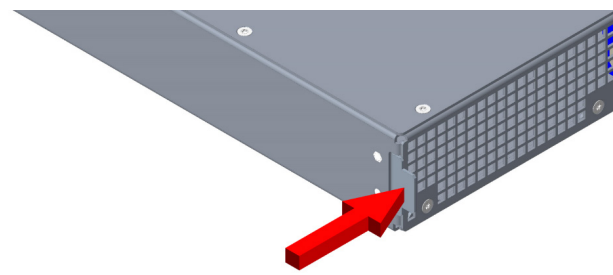

Connector Details

■ **AC Input Connector**

The power shelf has either one or two AC input connectors right only in the case of the single whip shelf PN. 700-015746-0100, or left and right in the case of the dual whip shelf PN. 700-015235-0100.

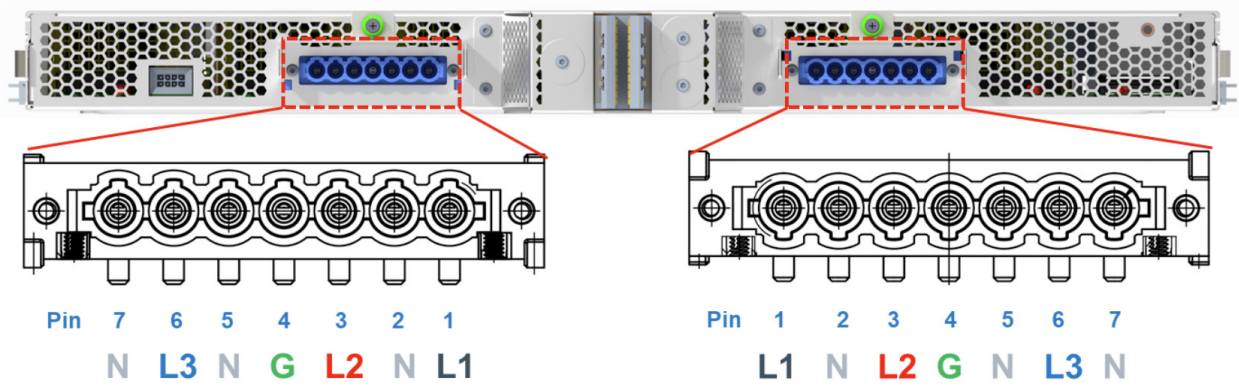

POWER SHELF INPUT WHIP REQUIREMENTS

This section provides details about the input connector specification and configuration to ensure proper wiring.

Input Wire shall use Positronic SP10RSSS1M2001/AA-2732 connector or equivalents to ensure proper fitting and operation. The Connector shall be rated for 30A or higher.

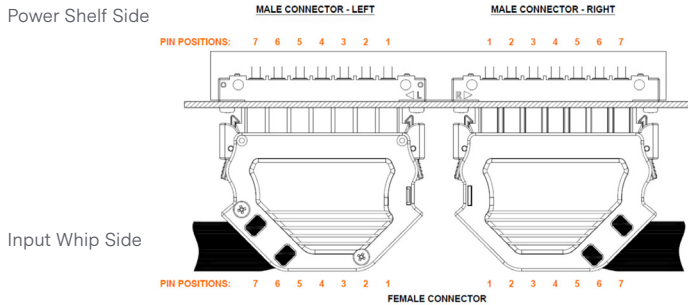

AC Input Connector Wiring

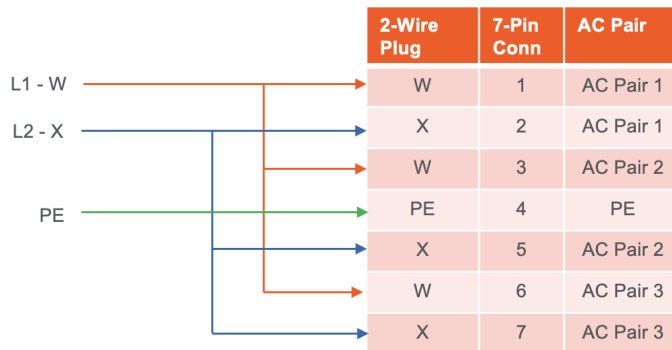
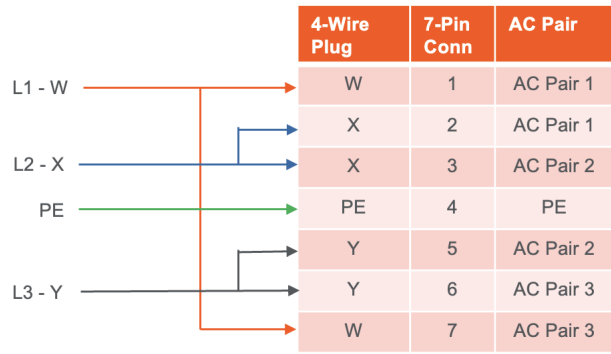
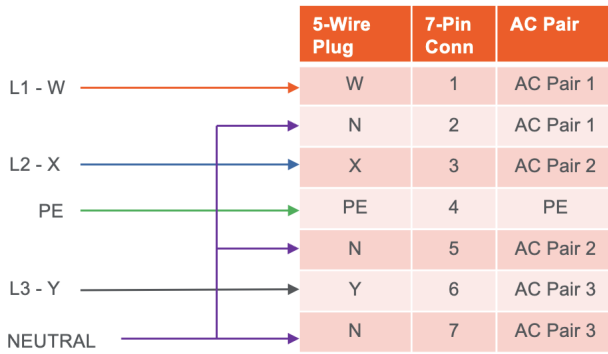

MECHANICAL

Power Supply Connector

The shelf contains the 6 blind mate mating connectors for the 6 ORv3 PSUs. Amphenol 10127400-01U1520LF or equivalent. This is a R/A receptacle, PwrBlade ULTRA HD connector with 3 low power pins, 25 signal pins, and 4 high power pins.

Rectifiers plug into the power shelf directly, and they are hot swappable while the rack is powered. Please refer to "Advanced Energy 50 V 5.5kW OPEN RACK V3 PSU" datasheet for pinout details. Below is input connector drawing

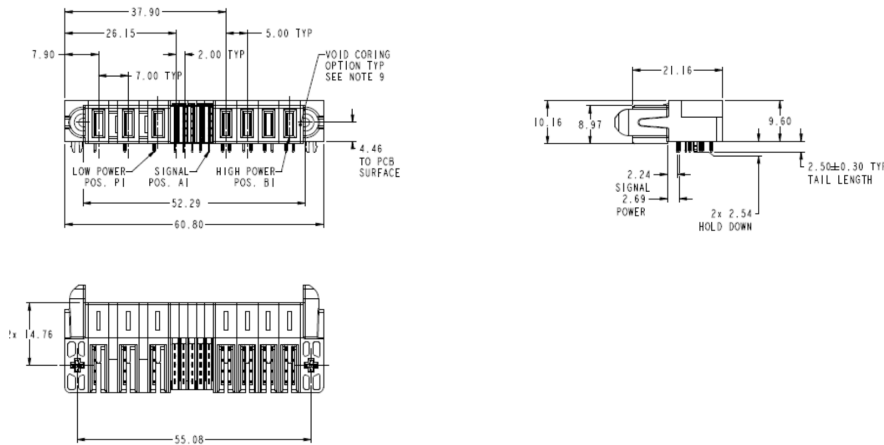

DC Output Connector

The shelf DC output connector is a floating blind mate connector that mates with ORv3 busbars in an ORv3 rack. This gives the flexibility for: Placing power and battery shelves any desirable location on the rack
Increasing power and energy by adding more power and/or battery shelves in the rack

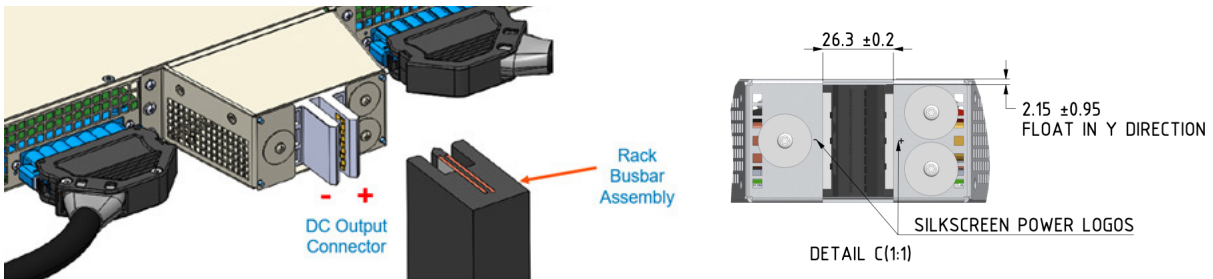

PMC/PMI/PMM Connector

The PMC is a blind-mate module with a 2C card edge connector. The PMC plugs into the power shelf directly, and is hot swappable while the rack is powered. Please refer to "Advanced Energy ORv3 STANDARD HPR PMC" datasheet for pinout details.

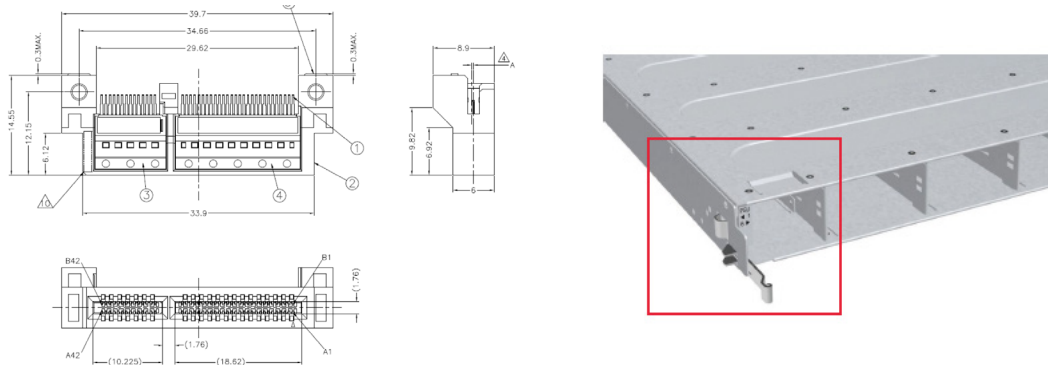

MECHANICAL

AC Loss Signal Connector

The shelf contains two RJ45 signal connectors on the rear of the power shelf to allow for an Input loss signal cable to be plugged between PSU & BBU shelf. For the interconnect a standard cat 5 or above cable is sufficient. Both RJ45 ports are daisy chained so shelves can be connected together. Please refer to below pin out:



RJ45 Port#1 Config

Pin#	Wire Color	Signal Name	Function
1	White/Orange	AL1	AC_LOSS signal from PSU 1
2	Orange	RSVD	reserved
3	White/Green	AL2	AC_LOSS signal from PSU 2
4	Blue	RSVD	reserved
5	White/Blue	AL3	AC_LOSS signal from PSU 3
6	Green	RSVD	reserved
7	White/Brown	PM	Pulse_Mgmt signal from 6 PSUs
8	Brown	SGND	signal ground

RJ45 Port#2 Config

Pin#	Wire Color	Signal Name	Function
1	White/Orange	AL4	AC_LOSS signal from PSU 4
2	Orange	RSVD	reserved
3	White/Green	AL5	AC_LOSS signal from PSU 5
4	Blue	RSVD	reserved
5	White/Blue	AL6	AC_LOSS signal from PSU 6
6	Green	RSVD	reserved
7	reserved	reserved	reserved
8	reserved	reserved	reserved

MECHANICAL

PSU-BBU Operation in ORv3 HPR

AC_LOSS_L and PULSE_MGMT signals have been added to ORv3 HPR PSU (Power Supply Unit) and BBU (Battery Backup Unit) design to enable control during Input loss events and repeated Power Surge. Each PSU has an output AC_LOSS_L and PULSE_MGMT signal, while each BBU has two input AC_LOSS_L signals and one PULSE_MGMT signal. These signals shall be routed to the rear of the Power or BBU Shelf to designated RJ45 connectors, as shown in below diagram.

PSU and BBU shelves AC_LOSS & PULSE_MGMT signal shall use standard Cat 5 or above cable to connect.

For detailed operation of AC_LOSS and PULSE_MGMT signal please refer to ORv3 HPR PSU specification.

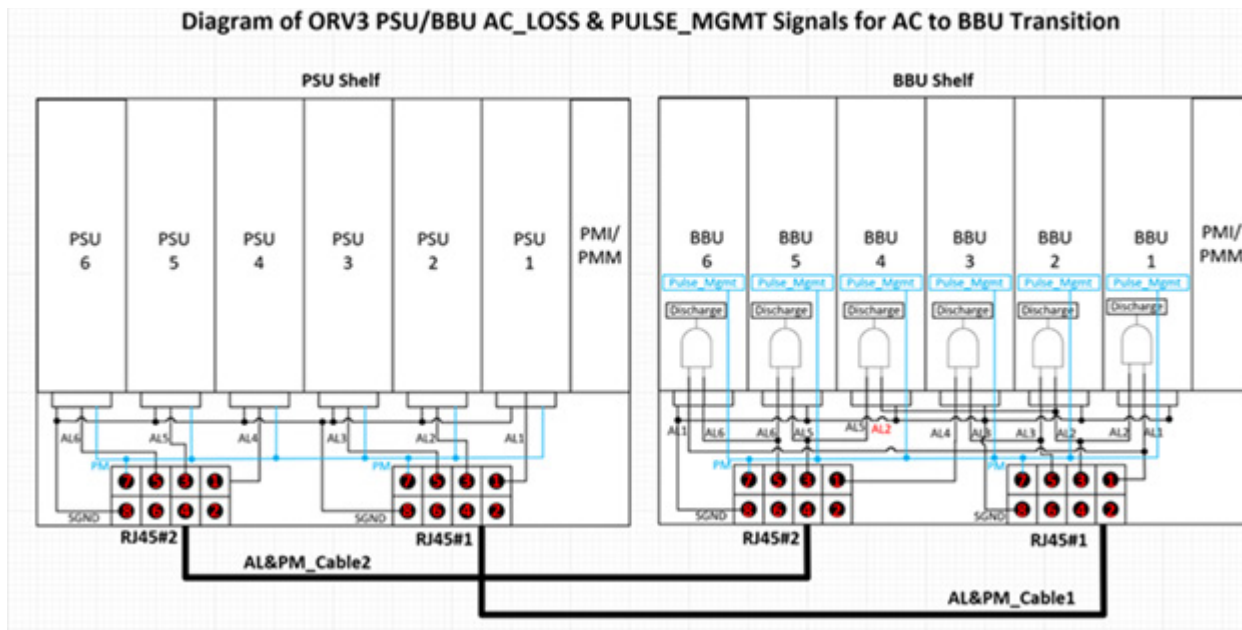

DEVICE	CONNECTOR	MATING CONNECTOR
Shelf	Input Connector: POSITRONIC SP10RSSS48RM220A1/AA-2731 SP10RSSS48M220A1/AA-2731	POSITRONIC SP10RSSS1M2001/AA-2732
	Output Connector: FCI BarKlip BK600 10164745-1SF025LF	ORv3 Busbars

MECHANICAL OUTLINE - POWER SHELF

Dual Whip Shelf

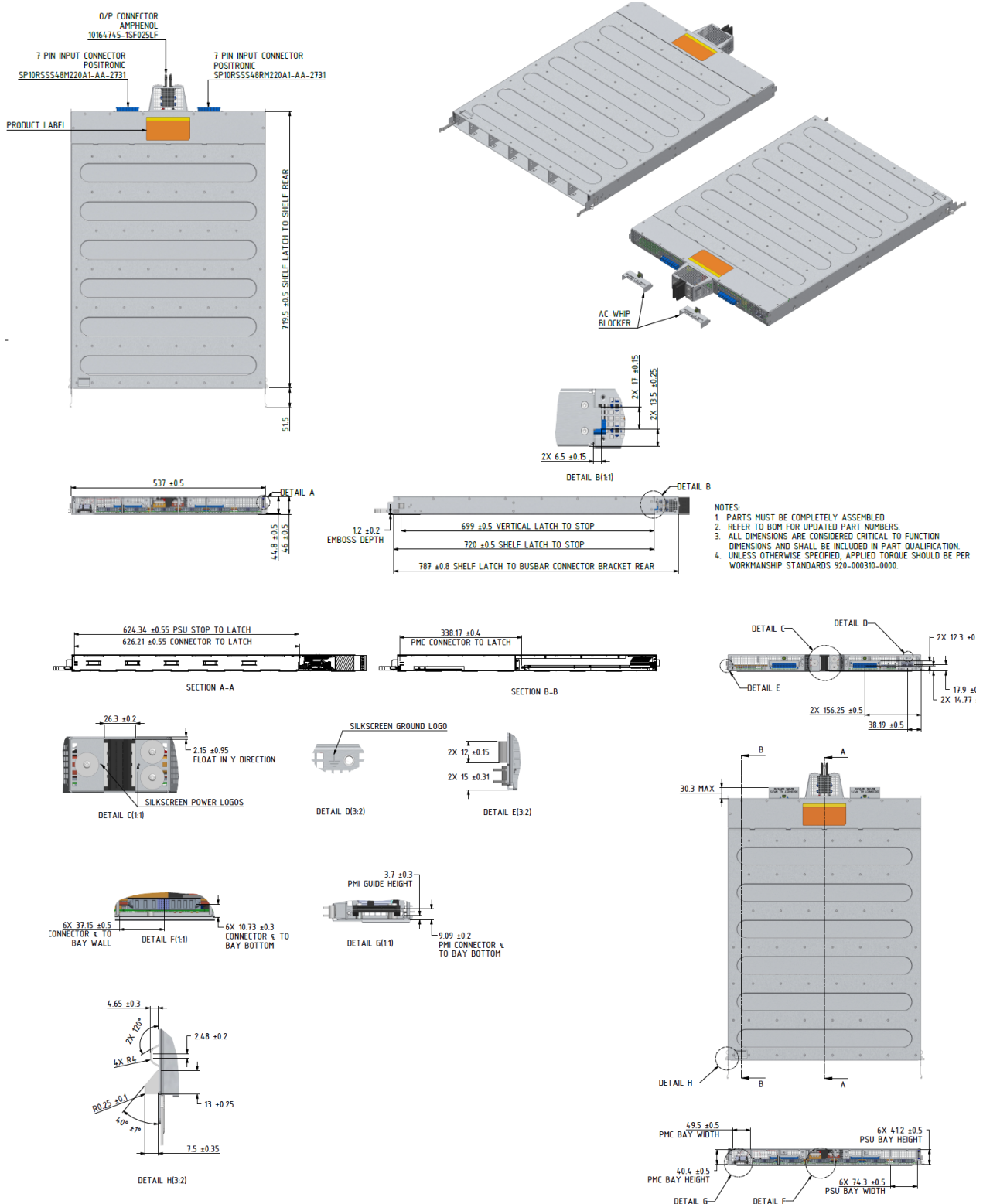

MECHANICAL OUTLINE - PSU

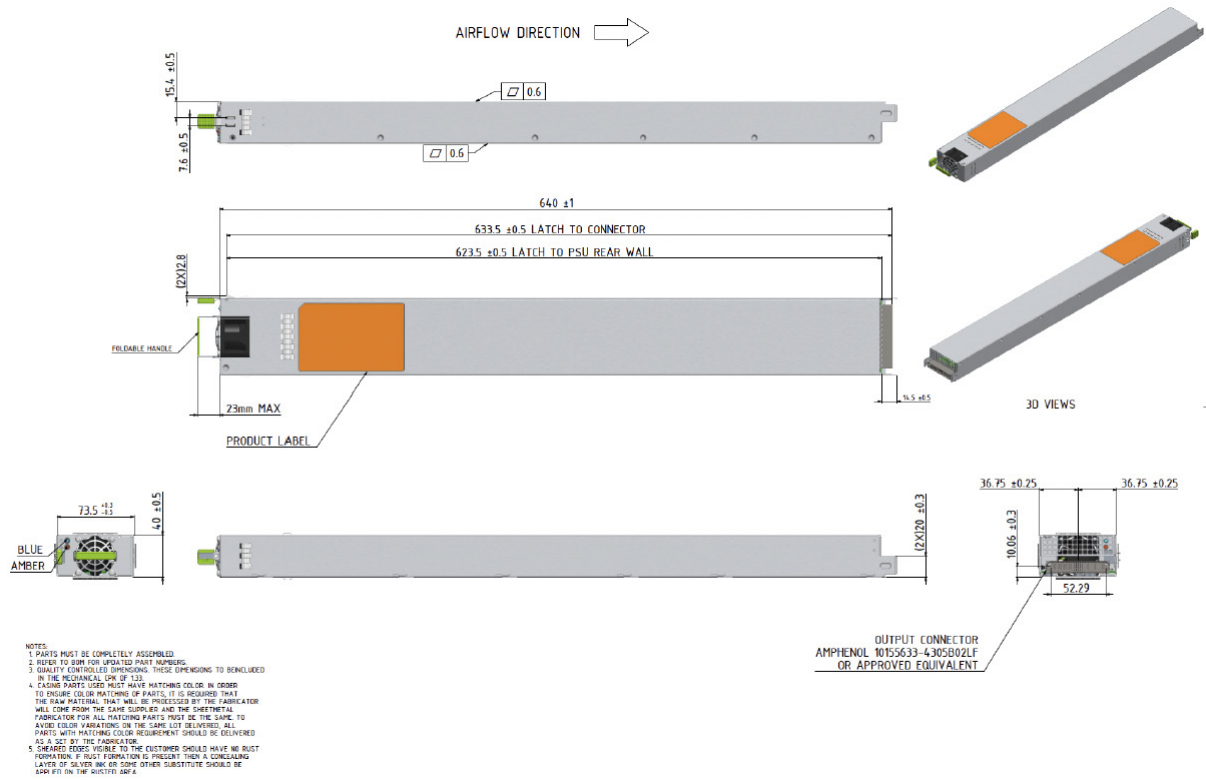

Unit: mm

MECHANICAL OUTLINE - PMI

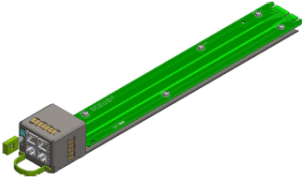

3D VIEW

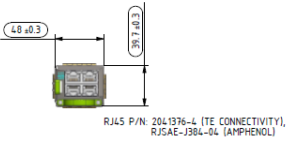
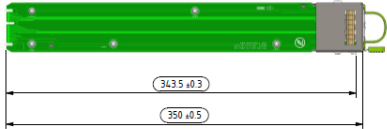

Unit: mm

THERMAL DESIGN

- Sensor accuracy: For discrete and critical sensors (such as ambient temperature) have an accuracy of $\pm 2^{\circ}\text{C}$
- Back-pressure: The shelf is designed to accommodate compliance requirements while ensuring reasonable impact to upstream components. A back-pressure of ≤ 0.15 inches of water is targeted.
- Bus-bar power or DC output connection assembly: Cables external to the shelf as well as the clip/connector (to the rack bus-bar) mounting at the rear panel are designed to ensure adequate cooling for compliance requirements (temperature difference as a function of current draw).
- Surface temperature: To make the shelf safe for handling in-operation, accessible surfaces should not exceed a temperature of 70°C .

ENVIRONMENTAL COMPLIANCE

- Gaseous contamination: Severity Level G1 per ANSI/ISA 71.04-1985
- Ambient operating temperature range: -5°C to $+45^{\circ}\text{C}$
- Operating and storage relative humidity: 10% to 90% (non-condensing)
- Storage temperature range: -40°C to $+70^{\circ}\text{C}$
- Transportation temperature range: -55°C to $+85^{\circ}\text{C}$ (short-term storage)
- Operating altitude with no de-ratings: 3,050 m (10,000 feet)
- Acoustic noise: Target sound pressure should not exceed 85 dBA when fan modules are running at full speed and operating within the defined environmental envelope

Vibration and Shock (Non-packaged)

The “power shelf with PSUs inside” meet vibration and shock test per EN 60068-2-6 and 60068-2-27, respectively, for both non-operating and operating condition, with the specifications listed below.

During operating vibration and shock tests, the PSU will exhibit full compliance to the specification without any electrical discontinuities.

During the non-operating tests, no damages of any kinds (included physical damages) should occur and they should not corrupt the functionalities of the PSU per the specifications.

Vibration Non-Operating:

Excitation Mode:	Sinusoidal
Test Frequency:	5 to 500 Hz (5 to 9 Hz) 6 mm peak to peak (9 to 500 Hz) 1 g
Amplitude:	1 g
Frequency Change Rate:	1 octave / min
Test Directions:	3 directions in space (x, y, z)
Duration:	10 sweep cycles for each direction (2 hours 13 minutes)
Test Temperature:	Room temperature
Electrical Work:	None

Shock Non-Operating:

Shock Pulse:	Half sinusoidal
Shock Duration:	11 ms
Shock Amplitude:	12 g
Test Directions:	6 directions
Number of Shocks:	60 (10 per each direction)
Test Temperature:	Room temperature
Electrical Work:	None

ENVIRONMENTAL COMPLIANCE

Vibration Operating

Excitation Mode	Sinusoidal
Test Frequency	5 to 500 Hz (5 to 9 Hz) 6 mm peak to peak (9 to 500 Hz) 1 g
Amplitude	0.5 g
Frequency Change Rate	1 octave / min
Test Directions	3 directions in space (x, y, z)
Duration	10 sweep cycles for each direction (2 hours 13 minutes)
Test Temperature	Room temperature
Electrical Work	Power supply in operation

Shock Operating:

Shock Pulse	Half sinusoidal
Shock Duration	11 ms
Shock Amplitude	6 g
Test Directions	6 directions
Number of Shocks	30 (5 per each direction)
Test Temperature	Room temperature
Electrical Work	Power supply in operation

Package Vibration, Drop and Compression

The power shelves (without PSUs) in their shipping package meet the following requirements:

Package Vibration	1.146 g, 2 to 200 to 2 Hz, all three axes, random vibrate	ISTA 3E 06-06
Package Drop	8-inch drop	ISTA 3E 06-06
Package Compression	Maximum compression loading on a bulk pack	ASTM D 642-94

EMC, SAFETY AND ENVIRONMENTAL COMPLIANCE

The power supply shelf is designed for compliance to allow worldwide deployment.

Safety Standards

The product is to be designed to comply with the latest edition, revision, and amendment of the following standards. The product is designed such that the end user could obtain the safety certifications: UL 62368-1, IEC 62368-1 and EN 62368-1; hazard-based performance standard for Audio video, IT & Communication Technology Equipment

- UL or an equivalent NRTL for the US with follow-up service (e.g. UL or CSA)
- CB certificate and test report issued by CSA, UL, VDE, TUV or DEMKO
- CE marking for EU

Component Safety Requirements

Following are the safety compliances for major components:

- All fans have the minimum certifications: UL and TUV or VDE.
- All current limiting devices have UL and TUV or VDE certifications and are suitable rated for the application where the device in its application complies with IEC/UL 62368-1.
- All printed wiring boards are rated UL94V-0 and sourced from a UL approved printed wiring board manufacturer.
- All connectors are UL recognized and have a UL flame rating of UL94V-0.
- All wiring harnesses are sourced from a UL approved wiring harness manufacturer. SELV cable to be rated minimum 80 V, 130°C.
- Product safety label will be printed on UL approved label stock and printer ribbon. Alternatively, labels can be purchased from a UL approved label manufacturer.
- The product will be marked with the correct regulatory markings to support the certifications that are specified in this document.

EMC Requirements

The power shelf meets the following requirements in the latest edition of standards when operating under typical load conditions and with all ports fully loaded.

The Power supply integrated into the shelf is called the component power supply.

The power shelf will have minimum 6dB margin from the Class A limit for the radiated and conducted emissions.

The following EMC Standards (the latest version) are applicable to the product:

- FCC /ICES-003
- CISPR 32/EN55032
- CISPR 35/EN55035 - Immunity
- EN61000-3-2 - Harmonics
- EN61000-3-3 - Voltage flicker
- VCCI
- KN 32 and KN35

Each individual basic standard for immunity test has the following minimum passing requirement. Higher level of passing criteria may be applied depending on the system manufacturer's design goals and business needs.

- EN61000-4-2 Electrostatic Discharge immunity
 - Contact discharge: > 5.6 kV
 - Air discharge: > 11.2 kV
- EN61000-4-3 Radiated immunity
 - > 3 V/m
- EN61000-4-4 Electrical Fast Transient immunity
 - AC power line: > 1 kV
 - Signal line: > 0.5 kV
- EN61000-4-5 Surge
 - AC power line: > 2 kV (Line-to-line), > 4 kV (Line-to-earth)
 - Signal port: > 1 kV

50 V 33 kW 10U ORv3 HPR POWER SHELVES

EMC, SAFETY AND ENVIRONMENTAL COMPLIANCE

- EN61000-4-6 Immunity to conducted disturbances
DC power line: > 3 Vrms
- EN61000-4-8 Power frequency magnetic field immunity, when applicable
> 1 A/m
- EN61000-4-11 Voltage dip and sag

Environmental Compliance

The power shelf (including all components inside) complies with the following minimum environmental requirements:

- RoHS Directive (2011/65/EU and 2015/863/EU)
- REACH Regulation (EC) No 1907/2006;
- Halogen Free: IEC 61249-2-21, Definition of Halogen Free, 900 ppm for Br or Cl, or 1500ppm combined
- US SEC conflict mineral regulation to source mineral materials from socially responsible countries, if applicable
- Waste Electrical and Electronic Equipment (“WEEE”) Directive (2012/19/EU) if applicable;
- Product does not contain any substances regulated by EPA 40 CFR751

ORDERING INFORMATION

Model	Description
700-037148-0100	Standard ORv3 HPR Power Shelf - Dual Whip

Model	Description
700-037147-0100	Standard ORv3 HPR 5.5 kW PSU
700-055176-0000	Standard ORv3 HPR PMC
700-037149-0100	Standard ORv3 HPR PMI
700-043397-0100	ORv3 HPR PMM



For international contact information,
visit [advancedenergy.com](https://www.advancedenergy.com).

powersales@aei.com (Sales Support)
productsupport.ep@aei.com (Technical Support)
+1 888 412 7832

ABOUT ADVANCED ENERGY

Advanced Energy (AE) has devoted more than four decades to perfecting power for its global customers. AE designs and manufactures highly engineered, precision power conversion, measurement and control solutions for mission-critical applications and processes.

Our products enable customer innovation in complex applications for a wide range of industries including semiconductor equipment, industrial, manufacturing, telecommunications, data center computing, and medical. With deep applications know-how and responsive service and support across the globe, we build collaborative partnerships to meet rapid technological developments, propel growth for our customers, and innovate the future of power.

PRECISION | POWER | PERFORMANCE | TRUST

Specifications are subject to change without notice. Not responsible for errors or omissions. ©2024 Advanced Energy Industries, Inc. All rights reserved. Advanced Energy®, AE® and Artesyn™ are U.S. trademarks of Advanced Energy Industries, Inc.