

ARTESYN OPEN RACK V3 5.5 kW 50 V HPR PSU

For 33kW 10U ORv3 HPR Power Shelves

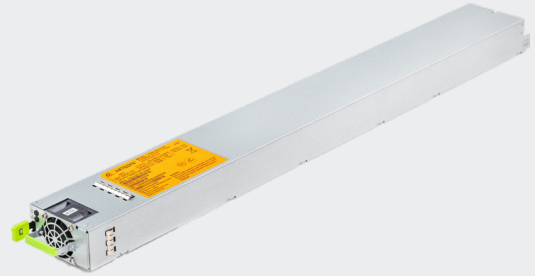

Advanced Energy's Artesyn introduces the ORv3 5.5 kW PSU for use in the Open Rack V3 HPR Power System. The PSU is a single-phase AC to DC power supply that operates from an input voltage range of 180 to 305 VAC and produces 50 V, 110A (5.5 kW) DC output. The ORV3 HPR PSU utilizes droop plus active current sharing, enabling six PSUs to operate in current sharing mode within the ORv3 10U HPR Power Shelf, producing 27.5 kW of N + 1 redundant power, or up to 33 kW per shelf in applications requiring multiple shelves in parallel, enabling 100 kW IT racks. In addition to an efficiency exceeding 97.5%, the PSU offers very high pulse load capability and a near unity power factor in response to dynamic loading, reducing the burden on the AC power infrastructure of the data center.

AT A GLANCE

Total Output Power

5.5 kW

Input Voltage

180 to 305 VAC

Output Voltage

50 to 49 VDC (0 to 100% load)

Mechanical Dimensions

640 x 73.5x 40 mm (L x W x H)

Operating Temperature

-5 to 45°C

KEY FEATURES

- Peak efficiency 97.5%
- Efficiency 96.5% from 30 to 100% load for 277 VAC
- 220 VAC to 277 VAC @ 5.5 kW
200 VAC @ 4.5 kW
- Active + Droop current sharing
- Hot swappable
- Cooling via internal fan with speed control
- Modbus communications
- Interface for monitoring and control
- Black box fault logging

EMC / SAFETY COMPLIANCE

- IEC EN 61000-4-5 CAT A surges
- EN 61000-3-2 Class A harmonics
- CISPR and FCC Part A EMC
- IEC/EN/UL 62368-1

ELECTRICAL SPECIFICATIONS

Absolute Maximum Ratings					
	Conditions	Min	Typ	Max	Unit
Input Voltage	AC continuous operation	180	-	305	VAC
Maximum Output Power		-	-	5.5	kW
Isolation Voltage	Input to outputs Input to safety ground				
Ambient Operating Temperature		-5	-	45	°C
Storage Temperature		-40	-	85	°C
Humidity (non-condensing)	Operating Non-operating	10 5	- -	90 93	% %
Altitude	Operating Non-operating	0 0	- -	3050 12000	m m
Input Specifications					
	Conditions	Min	Typ	Max	Unit
Input Voltage		180	200 to 277	305	VAC
Input AC Frequency		47	50/60	63	Hz
Input AC Start-up Voltage		-	177	-	VAC
Input AC Undervoltage Lockout Voltage		-	172	-	VAC
Fuse	Phase and return lines UL approved	25	-	-	kA
TON_noBBU		1	-	5	Sec
TON_BBU		1	-	8.5	Sec
T-Max_ON_noBBU		6	-	8	Sec
T-Max_ON_BBU		9.5	-	11.5	Sec
Inrush Current		-	-	42	A
Hold Up Time	220 to 277 VAC input 100% load	20	-	-	ms
iTHD	5% to 10% load 10% to 30% load 30% to 100% load	- - -	- - -	15 10 5	% % %
Power Factor	10% to 30% load VIN < 250V 10% to 30% load VIN > 250V 30% to 100% load	0.95 0.90 0.98	- - -	- - -	% % %
Efficiency	277 VAC input	-	-	97.5	%

ELECTRICAL SPECIFICATIONS

Output Specifications						
	Conditions	Min	Nom	Max	Unit	
Set Point	100% Load	48.875	49.000	49.125	VDC	
Output Current ¹		-	-	112	A	
Ripple & Noise ²	20MHz bandwidth	-	-	500	mVpp	
V _O Dynamic Response	Peak Deviation	10% min load				
		0 to 10 mF output cap.				
		Dynamic load @ 20Hz				
		Slew rate 1A/usec				
		50% step load	-	-	0.5	V
		90% step load	-	-	1.0	V
		140% step load	-	-	1.5	V
V _O Dynamic Response	Settling Time		3	-	ms	
Regulation and Droop Characteristics		0.375	0.5	0.625	V	
Current Sharing Accuracy	20 to 50% load	-5	-	+5	%	
	50 to 100% load	-2	-	+2	%	
Output Rise Time		-	60	-	ms	
Short Circuit Protection (SCP)	If the rectifier voltage is lower than 10 V (short circuit condition), the rectifier shuts off immediately. No component will damage. The protection is latch. Will only retry once if there is detected bus after 5 sec.					
Over Power / Current Protection (OCP)	Average power is more than 115% for 10s. Average power is more than 120% for 100ms.					
Overvoltage Protection (OVP)	The rectifier will shut down for DC output voltage exceeding 52.5 V and the reacting time will not exceed 200 ms. For DC output voltage will never exceed 54 V (fast OVP).					
Overtemperature Protection (OTP)	The rectifier employ over temperature protection for both ambient over temperature and internal thermal temperature to protect the rectifier. The rectifier will shut down under over temperature condition and recover after certain period after the over temperature condition is removed. The OTP circuit incorporate built in hysteresis such that the power supply does not oscillate on and off due to temperature recovering condition. The OTP event shall be reported as a fault condition.					

Note 1 - For surge current capabilities, see Pulse Load Operation.

Note 2 - Compliance will be verified using a 0.1 uF capacitor connected locally to the oscilloscope probe tips during this measurement.

PULSE LOAD OPERATION

PSU The power supply unit (PSU) should be capable of supporting the following peak load while maintaining output within regulation and without triggering the battery backup unit (BBU) to discharge.

- ≤136%, ≤50ms moving average,
- ≤160%, 400us moving average,
- ≤100%, ≥1s moving average.

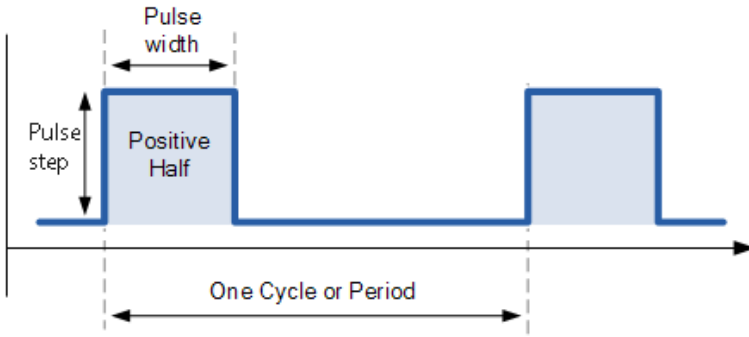

PSU-BBU OPERATION in ORv3 HPR

AC_LOSS_L and PULSE_MGMT signals have been added to ORv3 HPR PSU (Power Supply Unit) and BBU (Battery Backup Unit) design to enable control during Input loss events and repeated Power Surge. Each PSU has an output AC_LOSS_L and PULSE_MGMT signal, while each BBU has two input AC_LOSS_L signals and one PULSE_MGMT signal. These signals shall be routed to the rear of the Power or BBU Shelf to designated RJ45 connectors, as shown in below diagram.

PSU and BBU shelves AC_LOSS & PULSE_MGMT signal shall use standard Cat 5 or above cable to connect.

AC_LOSS Signal Operation

AC_LOSS_L signal assertion will be triggered by either condition1 or condition2 using a logic "OR" operation to ensure proper backup operation under all conditions. When a BBU receives both active AC_LOSS_L signals, it will pull the Sync_Start_L signal low, allowing the BBU shelf to initiate immediate discharge. The output voltage of the BBU shelf shall ramp up to the normal setting range within 2 ms.

Below two condition will trigger the AC_LOSS:

1. Upon detection of Input loss, the PSUs will assert the AC_LOSS_L signal after a validation delay of 4 to 5 ms.
2. AC_LOSS_L assertion will be based on the threshold of the remaining bulk capacitor energy, which should be kept at a minimum of >2 ms to allow sufficient time for the BBU to ramp up.

PULSE_MGMT Signal Operation

PULSE_MGMT signal assertion will be triggered by repetitive peak pulse loads, as they might occur in an GPU driven application. A adjustable predefined input power limit shall trigger PULSE_MGMT signal in case of depleting BULK capacitance beyond required energy reserve to trigger BBU Shelves Power Provisioning function to share the Output Bus bar load.

In case of no BBU Shelf availability or BBU refusal of load sharing (e.g. in case of too low State of Charge [SOC]), the PSU is allowed to increase the input power to it's maximum design capacity to carry the peak load.

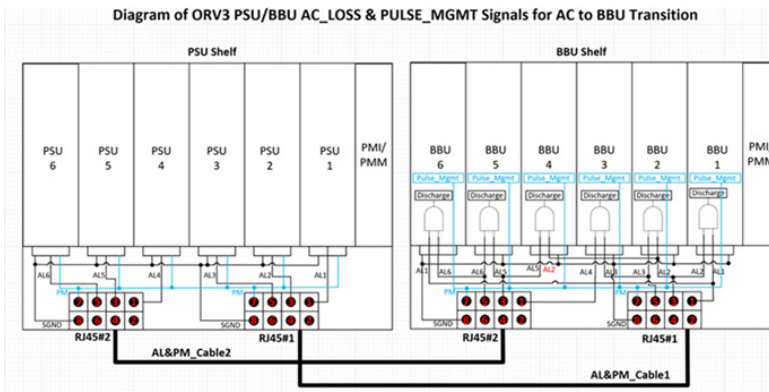

PROTECTION

Input Over Current Protection

The rectifier will incorporate primary fusing on both phase and return lines for input over-current protection to meet product safety requirements. Fuses will be selected to prevent nuisance trips. Fuse may be internal to unit and need not be user serviceable. AC inrush current will not cause the fuse to blow under any conditions. No rectifier operating condition will cause the fuse to blow unless a component in the rectifier has failed. This includes DC output overload and short-circuit conditions. Fuse will be approved by UL for an interrupt rating of at least 25 kA.

PSU fuse will be in coordination with datacenter tap box breaker curve as given below.

NEC breakers are 30 A, derating to 24A.(two AC feeds go to the power shelf – one PSU per input AC phase feed).

IEC breaker is normally 32 A (two AC feeds go to the power shelf, one PSU per input AC phase feed.)

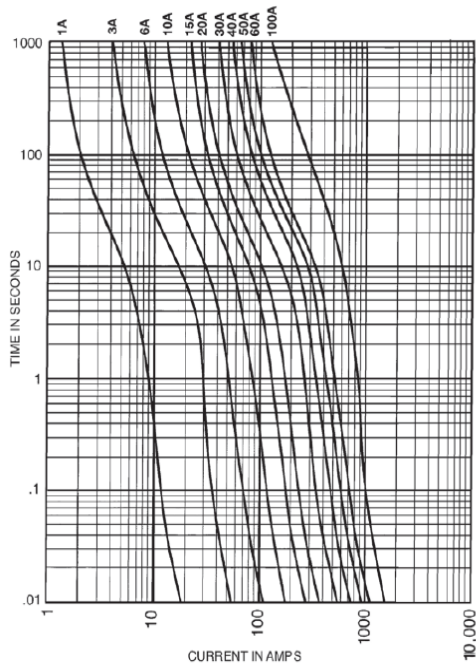

Input Over Voltage and Under Voltage Protection

The rectifier contain protection circuitry such that application of an input voltage below the minimum specified in section "Input Specification" on page 2 will not cause any damage to the rectifier and “softly shuts down” while operating. The rectifier will “softly shut down” if the input voltage is over 345 V for 20 ms or 309 V for 50 ms as shown in the graph below.

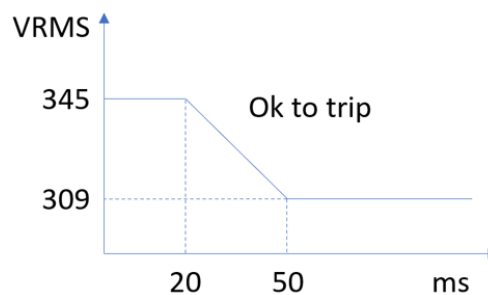

PROTECTION

Output Power / Current Protection

If a PSU is overloaded higher than the values listed below, it will shut down. 5s after an overload shut down, PSUs will retry once to sync together and turn on, if overload is still present, PSU will latch off. Latch can only be cleared through AC cycling, resetting or a MODbus command. OCP retry counter will be cleared 30mins. after normal operation.

- Average power more than 115% for 10 Sec.
- Average power more than 120% for 100 ms.

Output Short Protection

The rectifier includes short-circuit protection to protect the rectifier and attached load in the case of an output short-circuit or other output overload condition.

If the rectifier voltage is lower than 10 V (short circuit condition), the rectifier shuts off immediately. No component damage. The protection will be implemented with a hiccup mode. it tries to restart 5 times every 5 Sec and then locks out. PSUs will sync using sync_start after shut down to power up together.

Over Temperature Protection

The rectifier employ over temperature protection for both ambient over temperature and internal thermal temperature to protect the rectifier. The rectifier will “softly shut down” under over temperature condition and recover after certain period after the over temperature condition is removed. The OTP circuit incorporate built in hysteresis such that the power supply does not oscillate on and off due to temperature recovering condition. The OTP event will be reported as a fault condition.

TIMING - TBD

Random Timer and Synchronization

Under any conditions of dissipative load, capacitive load, temperature, with or without backup voltage connected to the PSU,

Max time for PSU to be “power-up ready” after AC voltage starts is 2.5 Sec.

After “power-up ready”:

When there is no DC voltage on the bus (first AC turn on) the power shelf will be randomized with 0 to 2 s window to give each power shelf a random turn-on time (six PSUs turn-on is synchronized).

When there is DC voltage on the bus higher than 44 V for 0.1 second (BBU is discharging), the power shelf will be randomized with 0 to 5.5 seconds window to give each power shelf a random turn-on time (six PSU turn-on is synchronized).

The power shelf will trun on with only 1 PSU inserted into any slot.

Note: The random numbers above will be dynamically generated immediately after each AC recycle, and not generated one time and then stored in the EEPROM for future usages.

Item	Description	Min	Max	Unit
T_power-up_ready	Time for PSU to be power-up ready	TBD	TBD	
T_random_noBBU	0 to 2 seconds initial turn on random delay without BBU discharging	-	5	Sec
Ton_noBBU	Time 51 VDC turns on after shelf receives AC input without BBU discharging.	TBD	TBD	
T_random_BBU	0 to 5.7 seconds turn on random delay after BBU discharging	TBD	TBD	
Ton_BBU	Time 51 VDC turns on after shelf receives AC input with BBU discharging.	-	8.5	Sec
Tsync	After all PSUs in the shelf are ready to start till when 51 VDC will start	TBD	TBD	
Tmax_ON_noBBU	Max PSU turn-on time without BBU in case of sync failure	-	8	Sec
Tmax_ON_BBU	Max PSU turn-on time with BBU in case of sync failure	-	11.5	Sec

TRANSITION AND SYNCHRONIZATION REQUIREMENTS

Start-up (0 V to 51 V) Transition Procedure

Each PSU has a small circuit as shown below and the circuit output (called SYNC_START) of all PSUs are connected together on the power shelf backplane.

- 1) Each PSU sets its uC Digital output signal (Do_SyncReady_L) to low when the PSU is ready to turn on the output.
- 2) Only PSU in SLOT #1 generates random timer and set Do_SyncReady_L to low when ready and random timer is finished.
- 3) The PSUs will turn on the output when the uC Digital input sync signal (DI_Sync_H) is high.
- 4) If DI_Sync_H kept stuck low for 3 Sec more than the max random timer limit (which is 2 s without BBU and 5.5 s with BBU), the PSU will turn on immediately.
- 5) If PSU1 is not installed or its Do_SyncReady_L stuck low, the other PSUs shall turn on when the DI_Sync_H is high. In this case random timer doesn't exist.

Please refer to section "Pulse Load Operation" on page 4 for the timing and constant current value requirements during the cold startup.

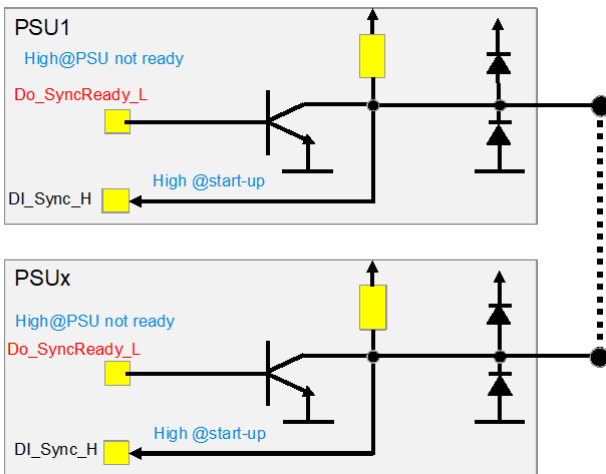

COMMUNICATIONS

The rectifiers can communicate on ModBus (up to 115 kbps).

At default, Modbus is active.

The software interface is operational when the AC is present or when the DC output bus is powered up by other power sources. The software provide below functions:

Fault conditions

- . Last power failure event
- . Rectifier failure

Read:

- . Voltage in
- . Current in
- . Voltage out
- . Current out
- . Temperatures
- . Fan speeds
- . Power out
- . Power in
- . Position
- . Serial Number
- . Manufacturer part number
- . Hardware revision
- . Firmware revision

Write:

- . Clear faults

Upgrades:

- . Upgrade firmware image (s)

Firmware Upgrade

The interface will allow the user to re-flash firmware on the device. Firmware upgrade shall result in no power interruption on the shelf level (the unit being upgrade can go offline.) Upgrades can be done 1 rectifier at a time.

The PSU FW shall maintain regulation on the output during send, Install and verification of the new FW, and only require a soft reset (that may reset the output for a short period in a few seconds).

PSU output voltage interruption due to FW upgrade will be less than 10 Sec.

COMMUNICATIONS

Reporting Accuracy

Accurate reporting of input power (power factor, input current, input current harmonics and voltage) and output power (output current and voltage) readings shall be reported via communication system at all rated voltage.

The accuracy will be maintained across the operating temperature range and between 180 VAC and 305 VAC.

Parameter	Load	Accuracy
AC Input Power	<10%	±25W
	10% to 20%	±5%
	20% to 100%	±3%
AC Input Current	<15%	±0.5A
	15% to 30%	±2%
	30% to 100%	±1%
AC Input Current THD (Error difference not %)	<10%	±10%
	10% to 30%	±2%
	30% to 100%	±1.5%
Power Factor (Error difference not %)	<10%	±0.1
	10 to 30%	±0.05
	30 to 100%	±0.01
AC Input Voltage	0 to 100%	±1%
Output Voltage	0 to 100%	±0.5%
Output Current	10 to 20%	±10%
	20 to 50%	±5%
	50 to 100%	±1%
Output Power	<10%	±25W
	10 to 20%	±3%
	20 to 100%	±2%

BLACKBOX FUNCTION

For the following section please refer to the latest Communication Specification for detailed information.

The black box function store key important data to be used when a fault occurs.

- . Store data in memory and can withstand several read/write cycles
- . PSU can store failure data before the PSU turns off/fails even in catastrophic failure events both on primary and secondary side. Hold up time of the blackbox microcontroller can store all the information and then shutdown.
- . Last 4 events stored in memory.
- . AC input current, AC input voltage, Input Power, Power factor, iTHD, DC output voltage, DC output current,
- . Temperature readings, fan Speed, input voltage, output voltage, bulk voltage, various error codes from all the different converters (OTP, OVP, OCP, UVP), and warnings.
- . BBU signals at time of failure (fail, charge_enable, BBU voltage, etc)
- . Total run time of PSU
- . Run time since last turn on
- . Real time stamping
- . Number of AC power cycles
- . Number of AC outages (can be determined by going into backup without counting the battery test conditions)

Power supply event data is saved to the Black Box for the following events that :

Any events that caused the Main Output to shut down:

- . Main Output over voltage fault
- . Main Output under voltage fault
- . Main Output over current fault
- . Main Output short circuit fault
- . Fan failure
- . Over temperature fault

Any events that caused the AC input to be bad:

- . AC Input under voltage fault
- . AC Input over voltage fault
- . AC Input out of range frequency fault

ENVIRONMENTAL SPECIFICATIONS

Temperature Range	Operational: -5 to +45°C; Non-operational: -40 to +85°C
Humidity	Operational: 10% to 90% non-condensing; Non-operational: 5% to 93% non-condensing
Altitude	Operational: 3050 m; Non-operational: 12000 m
Shock	EN 60068-2-6 and 60068-2-27 12g Non-Operating / 6g Operating
Vibration	EN 60068-2-6 and 60068-2-27 1g Non-Operating / 0.5g Operating
Fan noise	< 85 dBA, 100% load

THERMAL

Airflow Direction

Front-to-back

Fan Speed Control

The fan speed varies depending on ambient temperature and load and is optimized to maintain a temperature difference of 22°F nominally across 30 to 85% load range and up to 35°C inlet/ambient and 3050 m (10,000 ft) above sea-level. The benefit is reduced fan power usage.

System Back-pressure

Front-to-back airflow maintain for system backpressure up to minimum 0.3 inches of water.

Fan Failure

If a fan fails, the rectifier will indicate the failure with a signal that will be reported via software as well as an LED indicator on the front panel. The rectifier will not shut down because of a failed fan and will only shut down if there is a fault, ie. over-temperature fault.

Rectifier Thermal Monitoring

Inlet temperature, exhaust temperature, fan speed and fan fail signals are reported via communications. See Communications Section for details.

50 V 5.5 KW OPEN RACK V3 HPR PSU

MECHANICAL - POWER SHELF

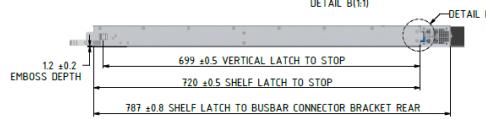
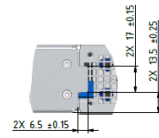
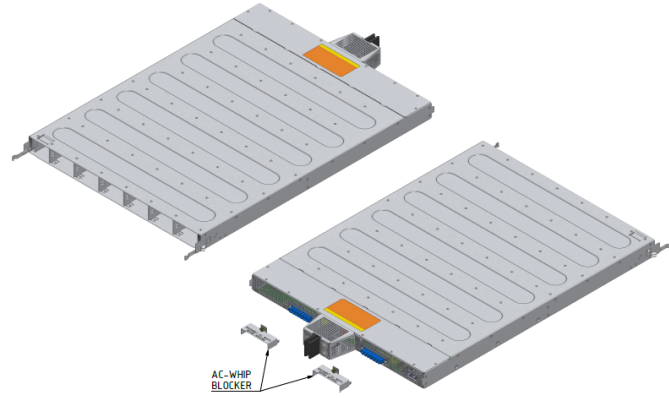
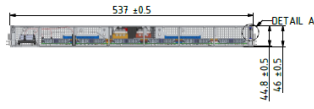
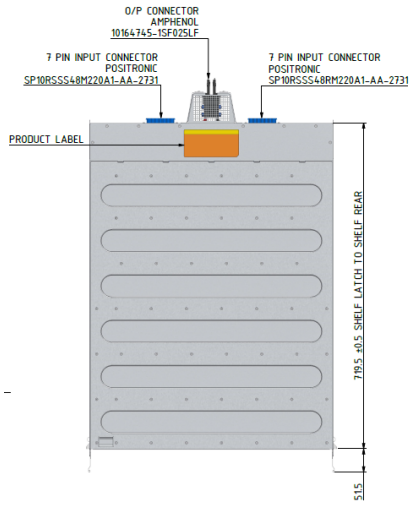

- NOTES:
1. PARTS MUST BE COMPLETELY ASSEMBLED
 2. REFER TO BOM FOR UPDATED PART NUMBERS.
 3. ALL DIMENSIONS ARE CONSIDERED CRITICAL TO FUNCTION DIMENSIONS AND SHALL BE INCLUDED IN PART QUALIFICATION
 4. UNLESS OTHERWISE SPECIFIED, APPLIED TORQUE SHOULD BE PER WORKMANSHIP STANDARDS 920-000310-0000.

PIN ASSIGNMENT

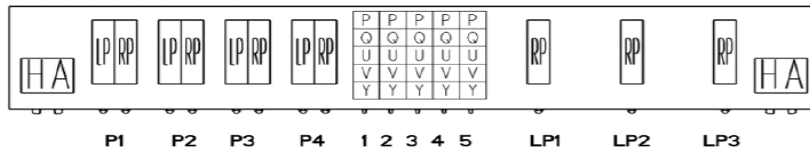

Pin	Name	Description
P1 & P2	Main Output+	
P3 & P4	Main Output Return	
LP1	Earth	
LP2	AC phase	
LP3	AC phase	
P1	PSU_A0	Address 0 - PSU ID A0, Internal pull up 10k to 3.3V
P2	PSU_A1	Address 1 - PSU ID A1, Internal pull up 10k to 3.3V
P3	PSU_A2	Address 2 - PSU ID A2, Internal pull up 10k to 3.3V
P4	Busbar_Clip+_Temp	Busbar clip + contact temperature Sensor
P5	Busbar_Clip+_Temp	Busbar clip return contact temperature Sensor
Q1	Ground	
Q2	Alert	Logic "low"= Fault or Warning, Logic "High"=OK, Internal pull up 10 k ohm to 3.3 V PSU Alert
Q3	Reset_Latch_Fault	Logic "high" for 1 to 2s = clear faults and start PSU to operate if not working due to a fault. Should be enabled by SW. Internal pull down 10 k ohm resistor.
Q4	Shelf_addr0	Internal pull up 100k ohm to 3.3V
Q5	Shelf_addr1	Internal pull up 100k ohm to 3.3V
U1	Shelf_addr2	Internal pull up 100k ohm to 3.3V
U2	AC_Loss_L	Open-collector/drain output, internal pull up 100k and a diode to 3.3V.
U3	PSKILL (Short Pin)	Logic "Low"= Output Turn on, Logic "High"= Output Turn off Quick shut down Output, mitigate hot unplug arcing. Internal pull up 10k to 3.3V
U4	RS485A	
U5	RS485B	
V1	Present_L	1. 10Ω pull-down inside PSU/BBU module. 2. 4.7k pull-up inside PMM. 3. Connecting to PMM edge connector pin A27/B27/A28/B28/A29/B29 respectively.
V2	I2C_SDA	I2C Data
V3	I2C_SCL	I2C Clock
V4	Ground	I2C ground
V5	Reserved	
Y1	ISHARE	Main output current share bus
Y2	AC_Fault_CLR	Open-collector/drain output; Internal pull up 100k and a diode to 3.3V
Y3	SYNC_START	Synchronizing turn-on main output, open-collector/drain output, Internal pull up 100k and a diode to 3.3V
Y4	Pulse_Mgmt_L	Logic "High"= no request for BBU support of pulse load Logic "Low"= request BBU support for pulse load. Open-collector/drain output, internal pull up 100k and a diode to 3.3V
Y5	Ground	

Note: P3, P4, and LP1 connect first. U3 is short pin.

50 V 5.5 kW OPEN RACK V3 HPR PSU

MATING CONNECTOR INFORMATION

Device	Connector	Mating Connector	Description
PSU	FCI: 10127396-01U1520LF (PwrBlade ULTRA HD)	FCI: 1027400-01U1520LF (PwrBlade ULTRA HD)	I/O Connector

LED



The PSU has a single blue and single amber LED mounted near the PSU handle for accessibility. Following are power supply LED states:

LED	Status	Description
Blue LED	Blinking Blue @ 4 Hz frequency	Sync Start State, PSU is ready to turn on its output and awaiting the sync Start signal
	Solid Blue	50 V is ON and available
	Off	50 V output off
Amber LED	Blinking Amber @ 4 Hz frequency:	Bootloading
	Solid Amber	Primary/Secondary/Fan/bootloading Failure and/or loss of DC output
	Off	fault NOT present/condition 1 and 2 are false

Note 1 - Toggling AC input power will reset the solid/blinking amber fault light but will come up again if faults re-occur.

Note 2 - Only one of the 3 conditions per LED will be applied at all time.

ORDERING INFORMATION

Model	Input	Output	Description
700-037147-0100	1 Phase AC, 180 to 305 VAC, 50 to 60 Hz	50 V  110 A	ACDC-ORv3 HPR - 5500W, ORv3 HPR PSU
700-037148-0100	3 Phase AC, 200/480 V, 50 to 60 Hz	50 V  550 A	ACDC-ORv3 HPR - 10U - 33 kW, ORv3 Power Shelf - Dual Whip std

Note 1 - TLA can only be ordered with previous LOA.



For international contact information,
visit [advancedenergy.com](https://www.advancedenergy.com).

powersales@aei.com (Sales Support)
productsupport.ep@aei.com (Technical Support)
+1 888 412 7832

ABOUT ADVANCED ENERGY

Advanced Energy (AE) has devoted more than three decades to perfecting power for its global customers. AE designs and manufactures highly engineered, precision power conversion, measurement and control solutions for mission-critical applications and processes.

Our products enable customer innovation in complex applications for a wide range of industries including semiconductor equipment, industrial, manufacturing, telecommunications, data center computing, and medical. With deep applications know-how and responsive service and support across the globe, we build collaborative partnerships to meet rapid technological developments, propel growth for our customers, and innovate the future of power.

PRECISION | POWER | PERFORMANCE | TRUST

Specifications are subject to change without notice. Not responsible for errors or omissions. ©2024 Advanced Energy Industries, Inc. All rights reserved. Advanced Energy®, AE® and Artesyn™ are U.S. trademarks of Advanced Energy Industries, Inc.